



US00D805416S

(12) **United States Design Patent**
Rymer et al.

(10) **Patent No.:** **US D805,416 S**

(45) **Date of Patent:** **** *Dec. 19, 2017**

(54) **WAVE-SHAPED ROADWAY RUMBLE STRIP**

(71) Applicant: **State of California, Department of Transportation**, Sacramento, CA (US)

(72) Inventors: **Bruce C. Rymer**, Sacramento, CA (US); **Paul R. Donovan**, Petaluma, CA (US)

(*) Notice: This patent is subject to a terminal disclaimer.

(**) Term: **15 Years**

(21) Appl. No.: **29/544,678**

(22) Filed: **Nov. 5, 2015**

Related U.S. Application Data

(63) Continuation-in-part of application No. 29/541,381, filed on Oct. 2, 2015.

(51) **LOC (10) Cl.** **10-05**

(52) **U.S. Cl.** **D10/113.1**
USPC

(58) **Field of Classification Search**
USPC D10/113.1, 113.3

(Continued)

(56) **References Cited**

U.S. PATENT DOCUMENTS

5,327,850 A * 7/1994 Sly E01F 9/553
116/6 P
5,392,728 A * 2/1995 Speer E01F 9/553
116/63 R

(Continued)

Primary Examiner — George D Kirschbaum

(74) *Attorney, Agent, or Firm* — Craig H. Simmermon

(57) **CLAIM**

The ornamental design for wave-shaped roadway rumble strip, as shown and described.

DESCRIPTION

FIG. 1 is a top perspective view of a wave-shaped roadway rumble strip showing my new design

FIG. 2 is a top plan view thereof.

FIG. 3 is a longitudinal cross sectional view taken along the lines 3-3 in FIG. 2 thereof.

FIG. 4 is a lateral cross sectional view taken along the lines 4-4 in FIG. 2 thereof.

FIG. 5 is an enlarged view thereof.

FIG. 6 is another top perspective view thereof.

FIG. 7 is another top plan view thereof.

FIG. 8 is a top perspective view of a second embodiment of my design.

FIG. 9 is a top plan view thereof.

FIG. 10 is a longitudinal cross-sectional view taken along the lines 10-10 in FIG. 9 thereof.

FIG. 11 is a lateral cross sectional view taken along the lines 11-11 in FIG. 9 thereof.

FIG. 12 is an enlarged view thereof.

FIG. 13 is another top perspective view thereof.

FIG. 14 is another top plan view thereof.

FIG. 15 is a top perspective view of a third embodiment of my design.

FIG. 16 is a top plan view thereof,

FIG. 17 is a longitudinal cross sectional view taken along the lines 17-17 in FIG. 16 thereof,

FIG. 18 is a longitudinal cross sectional view taken along the lines 18-18 in FIG. 16 thereof,

FIG. 19 is an enlarged view thereof.

FIG. 20 is a partial top perspective view thereof.

FIG. 21 is another top plan view thereof.

FIG. 22 is top perspective view of a fourth embodiment of my design.

FIG. 23 is a top plan view thereof,

FIG. 24 is a longitudinal cross sectional view taken along the lines 24-24 in FIG. 23 thereof.

FIG. 25 is a longitudinal cross sectional view taken along the lines 25-25 in FIG. 23 thereof,

FIG. 26 is an enlarged view thereof.

FIG. 27 is a partial top perspective view thereof.

FIG. 28 is another top plan view thereof,

FIG. 29 is top perspective view of a fourth embodiment of my design,

FIG. 30 is a top plan view thereof,

FIG. 31 is a longitudinal cross sectional view taken along the lines 31-31 in FIG. 30 thereof.

(Continued)

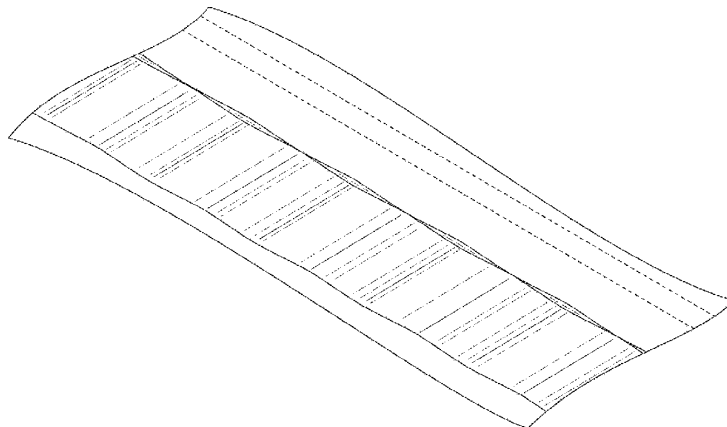

FIG. 32 is a longitudinal cross sectional view taken along the lines 32-32 in FIG. 30 thereof.
 FIG. 33 is an enlarged view thereof.
 FIG. 34 is a partial top perspective view thereof.
 FIG. 35 is another top plan view thereof.
 FIG. 36 is top perspective view of a fifth embodiment of my design.
 FIG. 37 is a top plan view thereof.
 FIG. 38 is a longitudinal cross sectional view taken along the lines 38-38 in FIG. 37 thereof,
 FIG. 39 is a longitudinal cross sectional view taken along the lines 39-39 in FIG. 37 thereof,
 FIG. 40 is an enlarged view thereof.
 FIG. 41 is a partial top perspective view thereof.
 FIG. 42 is another top plan view thereof.
 FIG. 43 is top perspective view of a sixth embodiment of my design.
 FIG. 44 is a top plan view thereof,
 FIG. 45 is a longitudinal cross sectional view taken along the lines 45-45 in FIG. 44 thereof,
 FIG. 46 is a longitudinal cross sectional view taken along the lines 46-46 in FIG. 44 thereof.
 FIG. 47 is an enlarged view thereof.
 FIG. 48 is a partial top perspective view thereof.
 FIG. 49 is another top plan view thereof.
 FIG. 50 is top perspective view of a seventh embodiment of my design.
 FIG. 51 is a top plan view thereof,
 FIG. 52 is a longitudinal cross sectional view taken along the lines 52-52 in FIG. 51 thereof,
 FIG. 53 is a longitudinal cross sectional view taken along the lines 53-53 in FIG. 51 thereof,
 FIG. 54 is an enlarged view thereof.
 FIG. 55 is a partial top perspective view thereof.
 FIG. 56 is another top plan view thereof.
 FIG. 57 is top perspective view of an eighth embodiment of my design.

FIG. 58 is a top plan view thereof.
 FIG. 59 is a longitudinal cross sectional view taken along the lines 59-59 in FIG. 58 thereof.
 FIG. 60 is a longitudinal cross sectional view taken along the lines 60-60 in FIG. 58 thereof.
 FIG. 61 is an enlarged view thereof.
 FIG. 62 is a partial top perspective view thereof; and,
 FIG. 63 is another top plan view thereof.
 Broken lines in the drawings represent unclaimed environmental subject matter and form no part of the claimed design.

1 Claim, 54 Drawing Sheets

(58) **Field of Classification Search**
 CPC E01F 9/553; E01F 9/512; E01F 9/529;
 G01M 17/06; E01C 5/08
 See application file for complete search history.

(56) **References Cited**

U.S. PATENT DOCUMENTS

5,769,563	A *	6/1998	Flynn	E01F 9/512
					116/63 P
7,118,305	B1 *	10/2006	Corbett	E01F 13/12
					404/6
7,302,825	B2 *	12/2007	Knox	G01M 17/06
					73/11.04
7,625,152	B2 *	12/2009	Swamidass	E01F 9/529
					404/12
7,731,448	B2 *	6/2010	Fillie	E01F 9/529
					404/15
7,736,087	B1 *	6/2010	Mettler	E01F 9/529
					116/63 P
7,950,276	B1 *	5/2011	Freyhof	E01O 5/08
					73/146

* cited by examiner

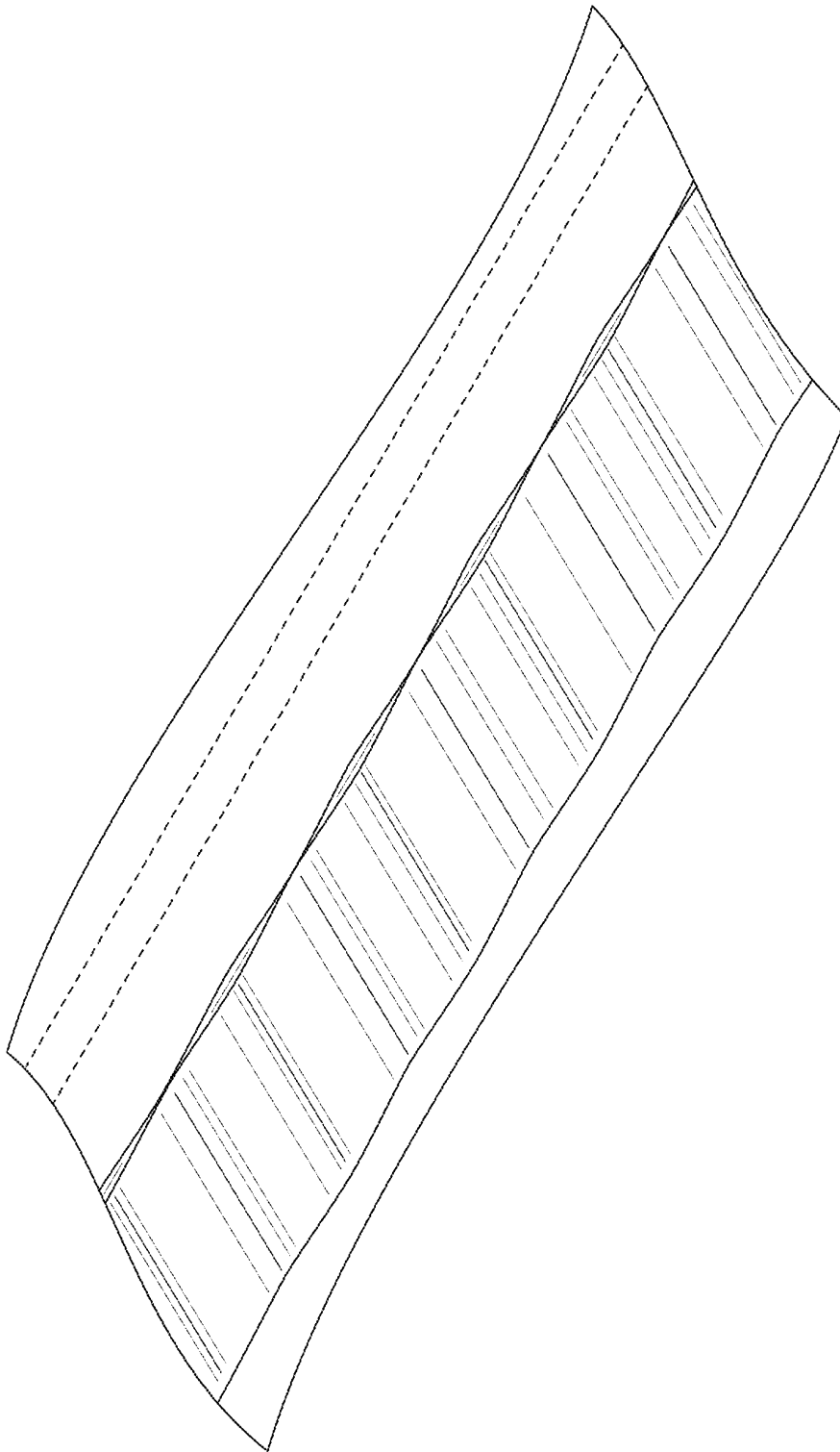

FIG. 1

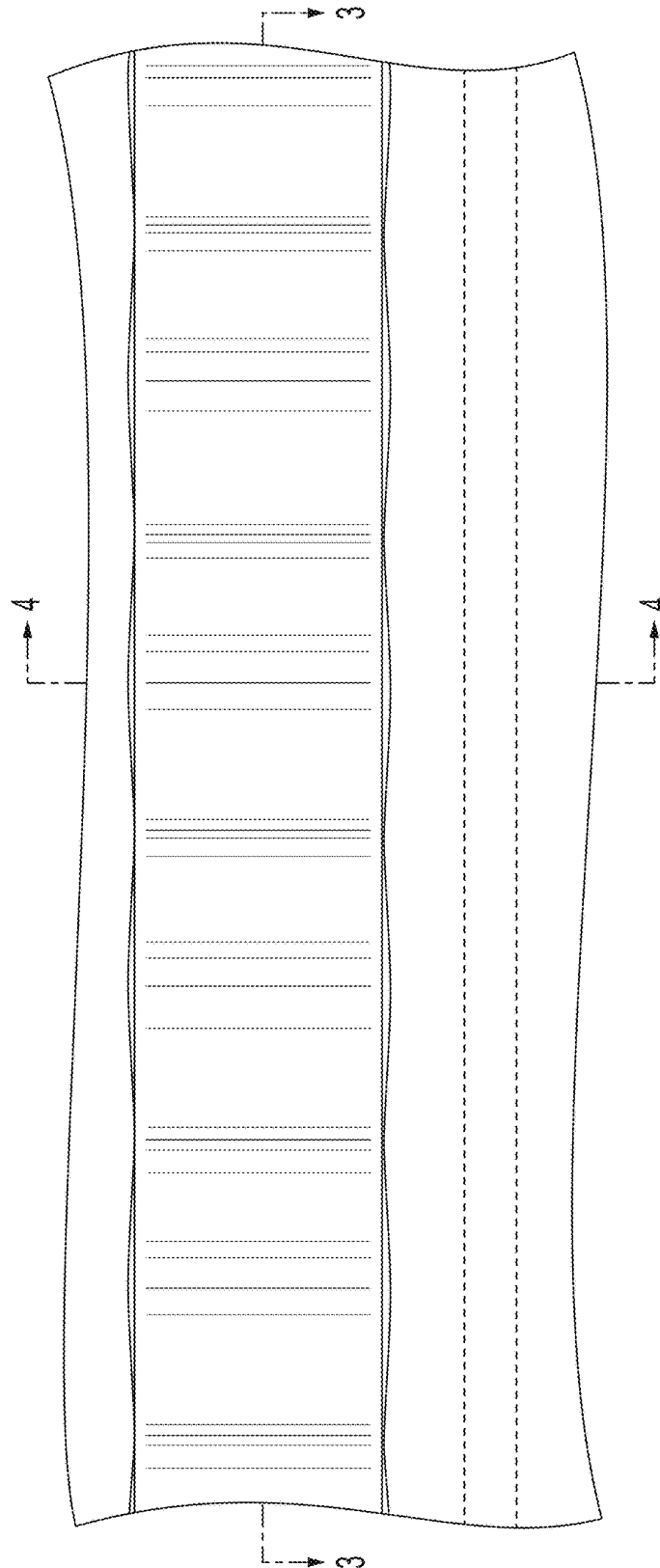

FIG. 2



FIG. 3



FIG. 4

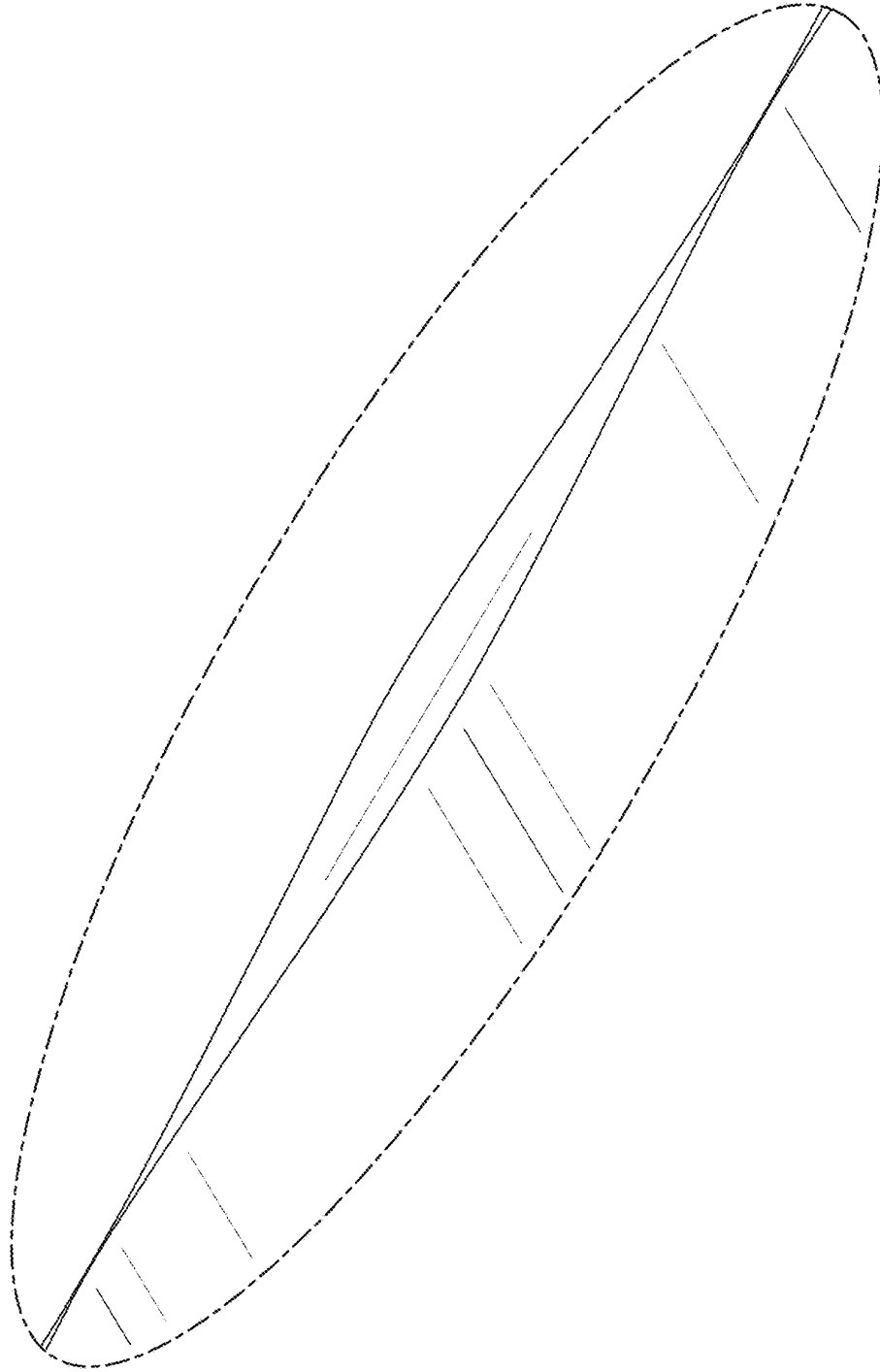

FIG. 5

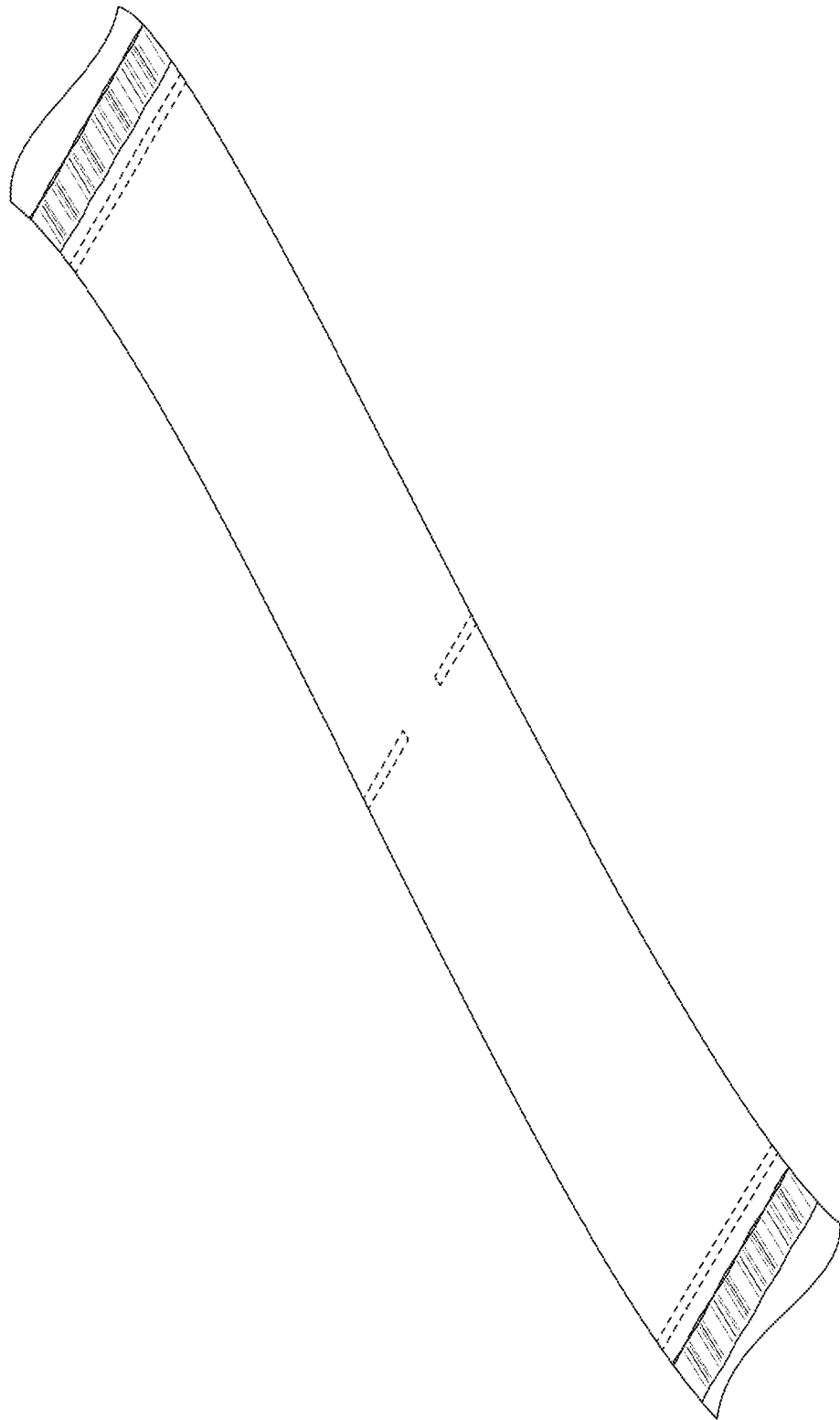

FIG. 6

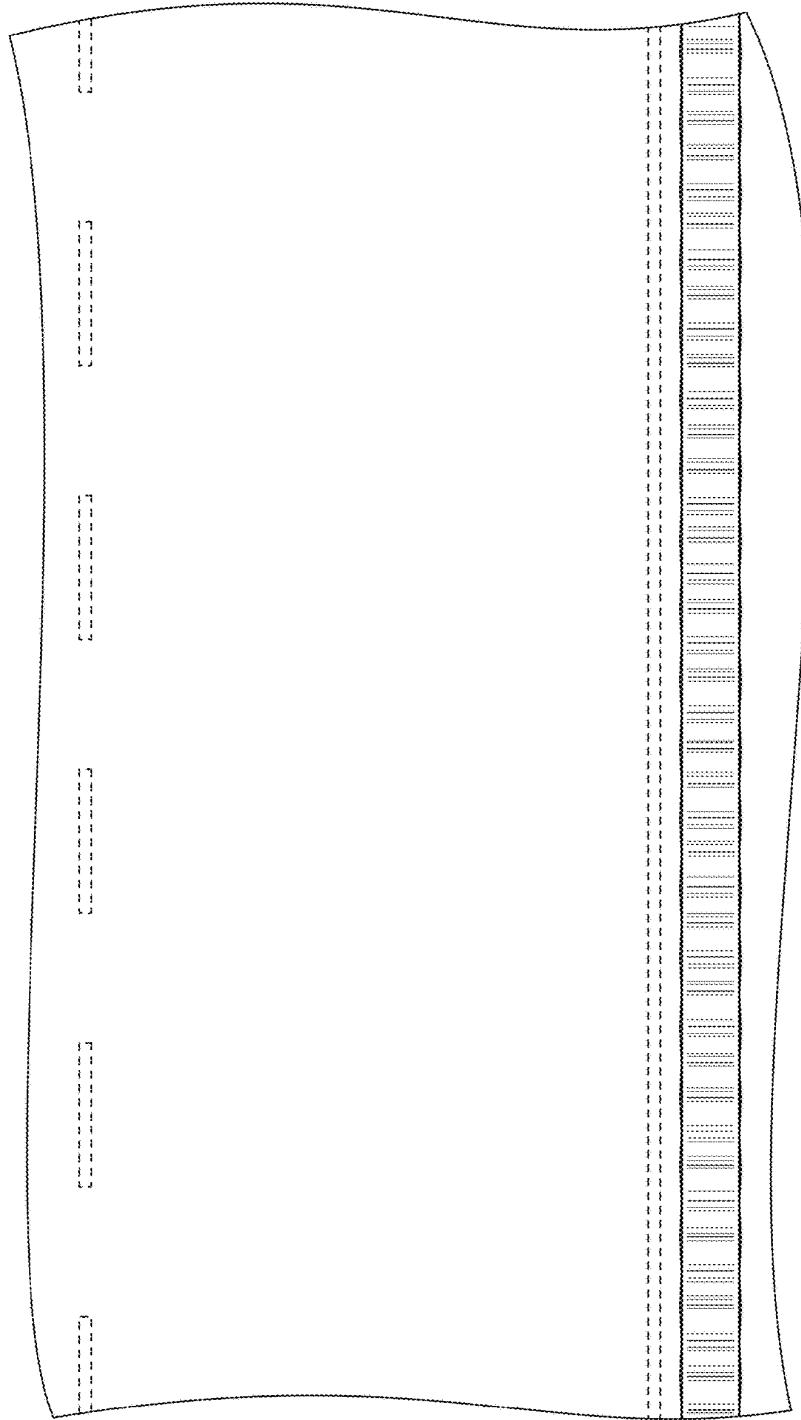

FIG. 7

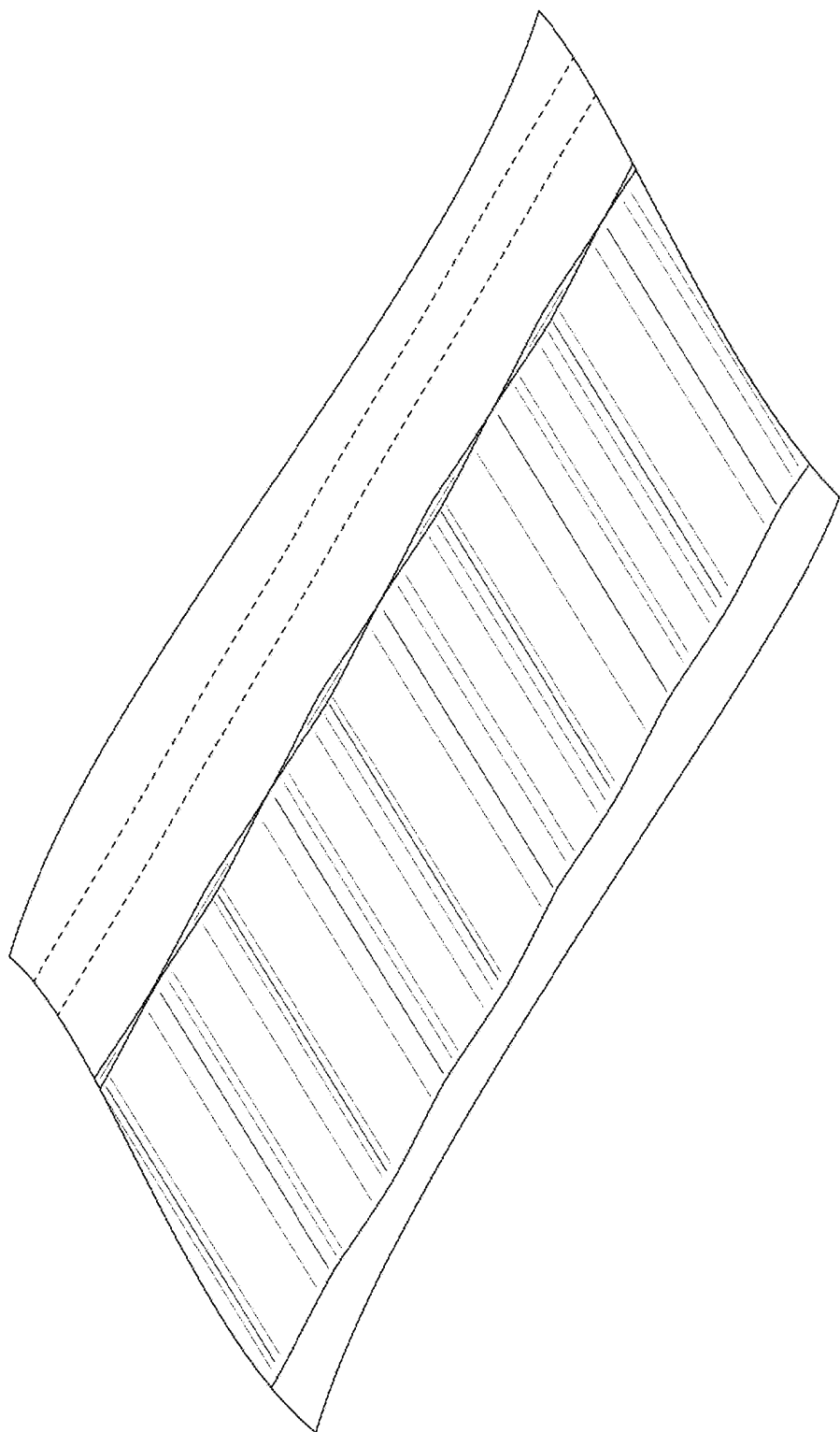

FIG. 8

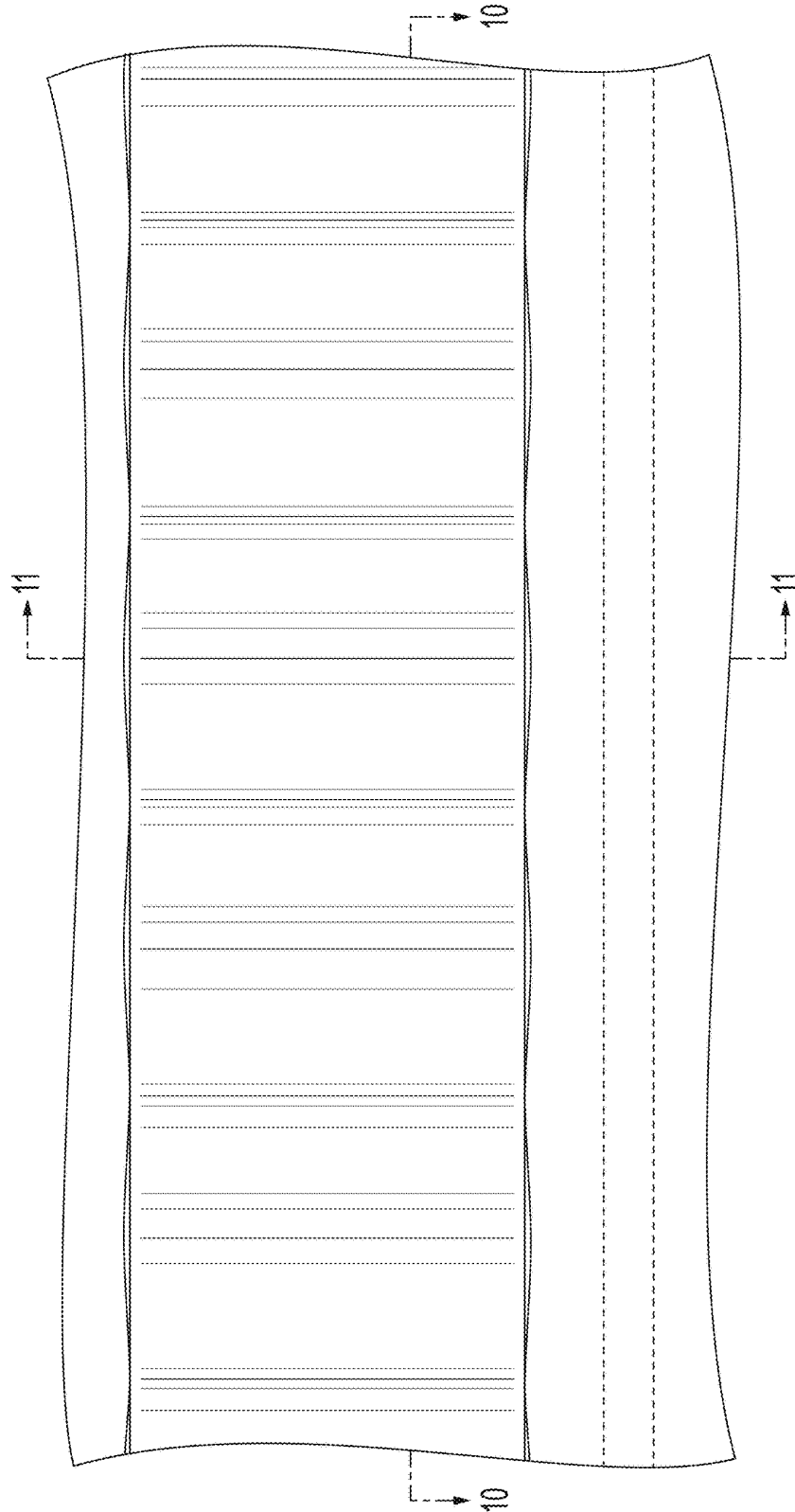

FIG. 9



FIG. 10

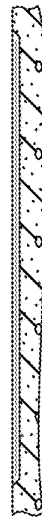

FIG. 11

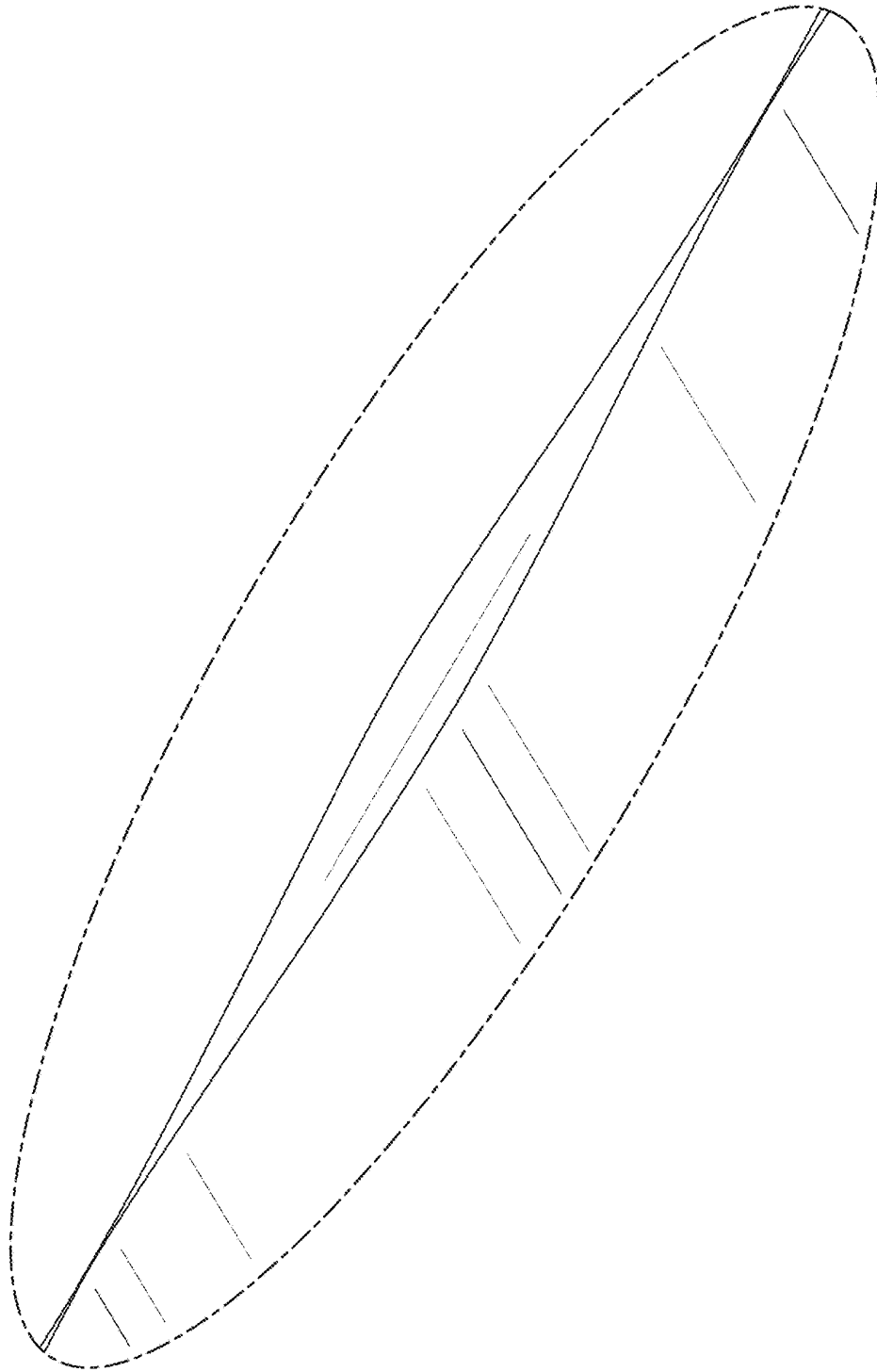

FIG. 12

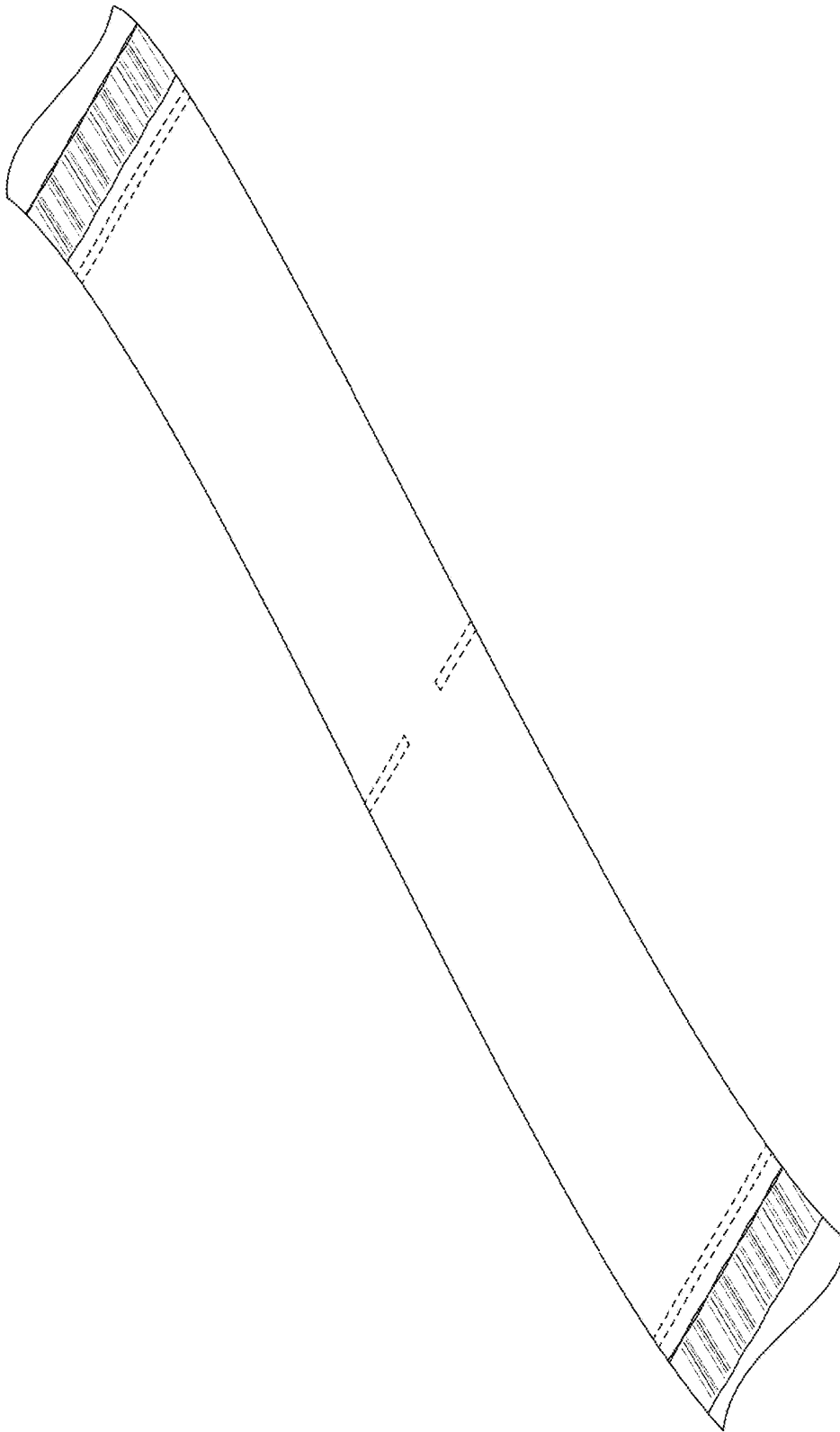

FIG. 13

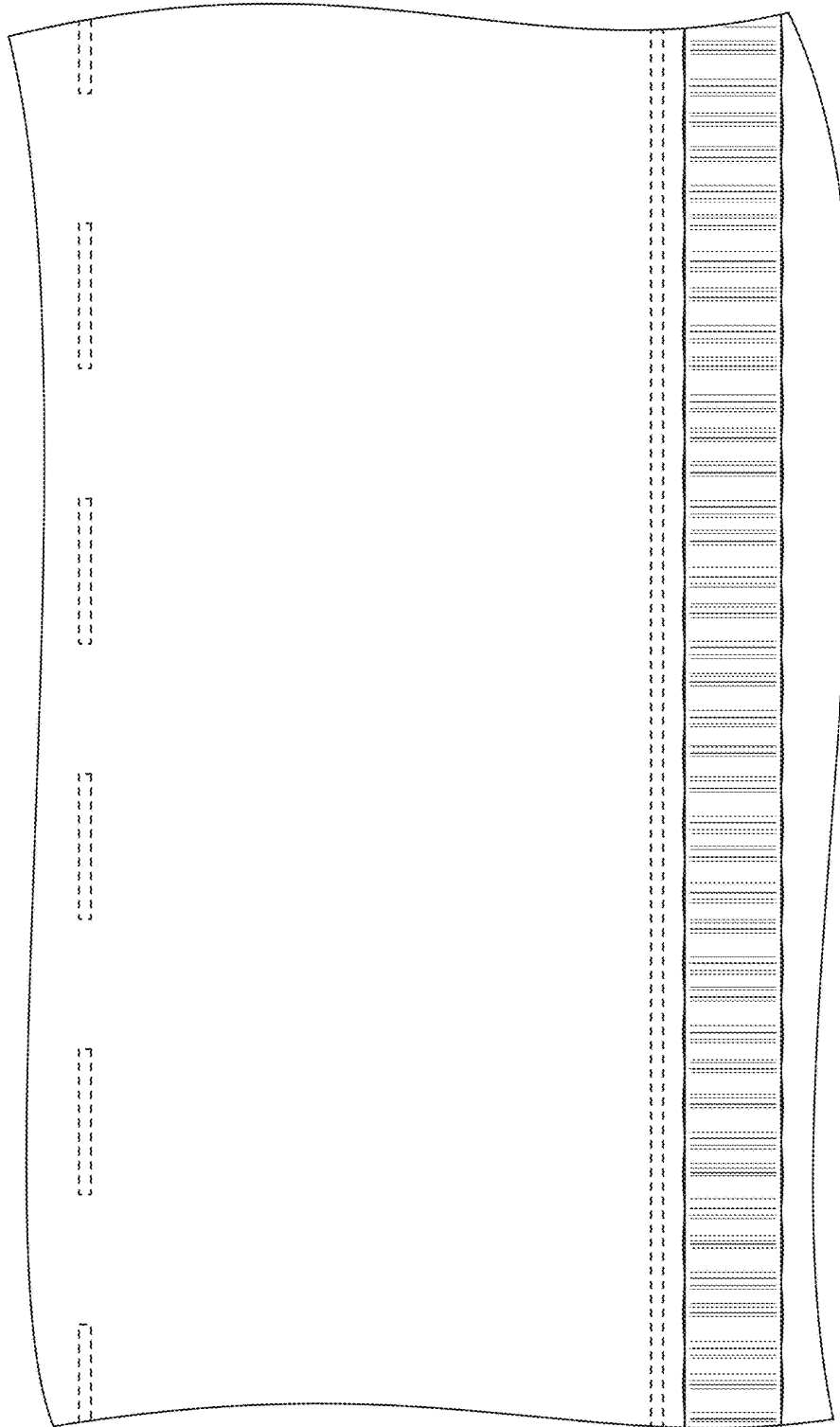

FIG. 14

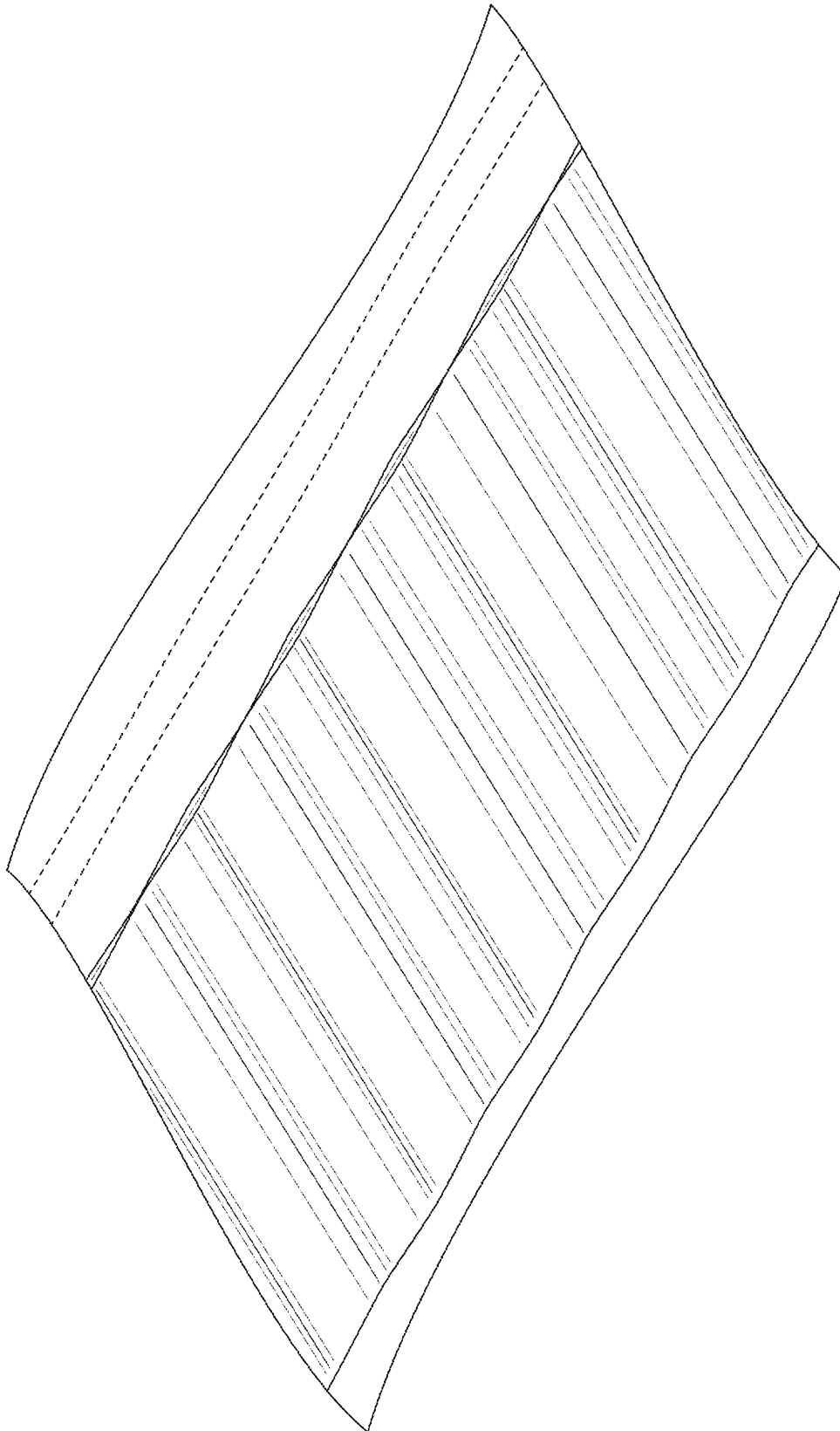

FIG. 15

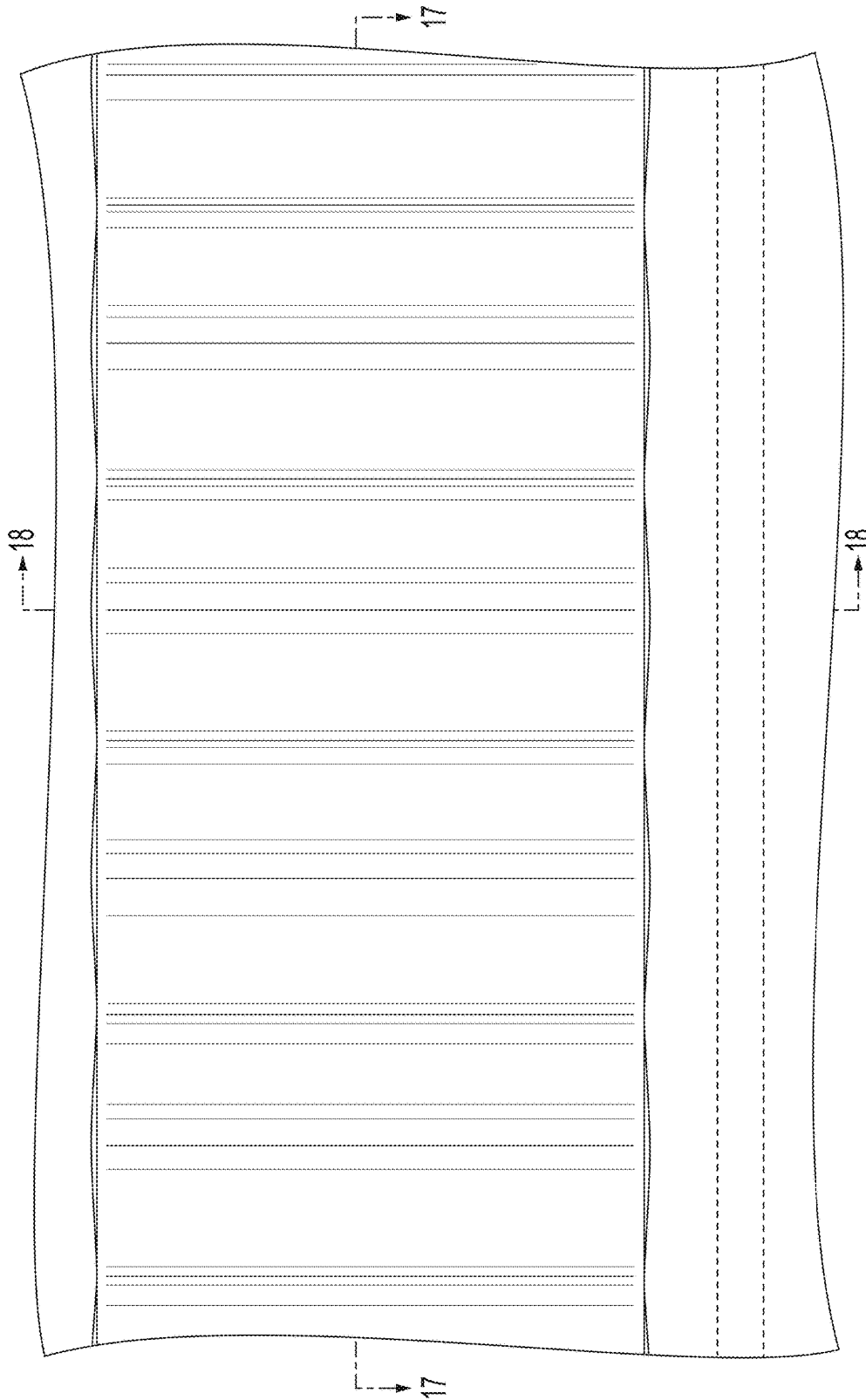

FIG. 16



FIG. 17



FIG. 18

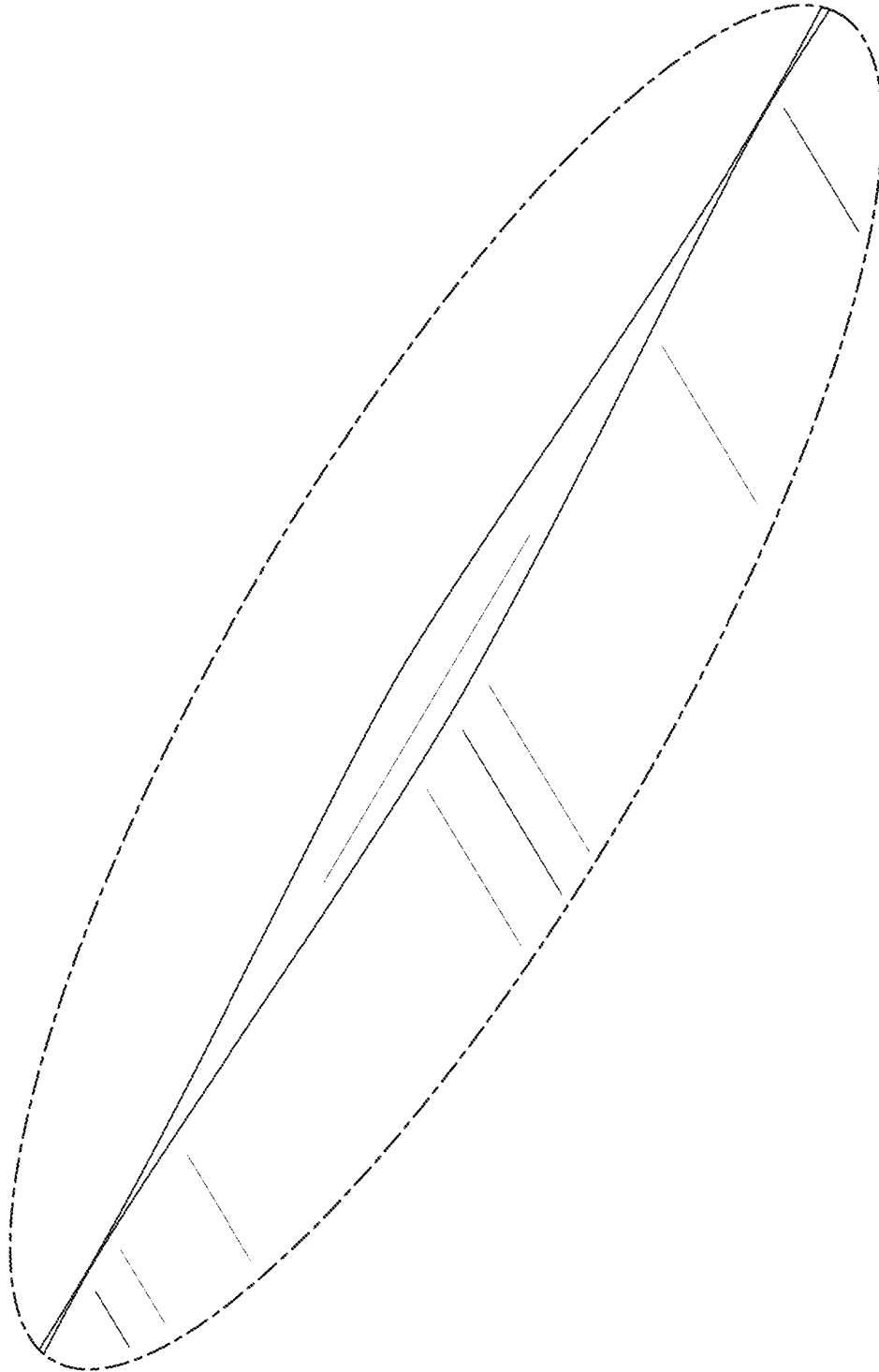

FIG. 19

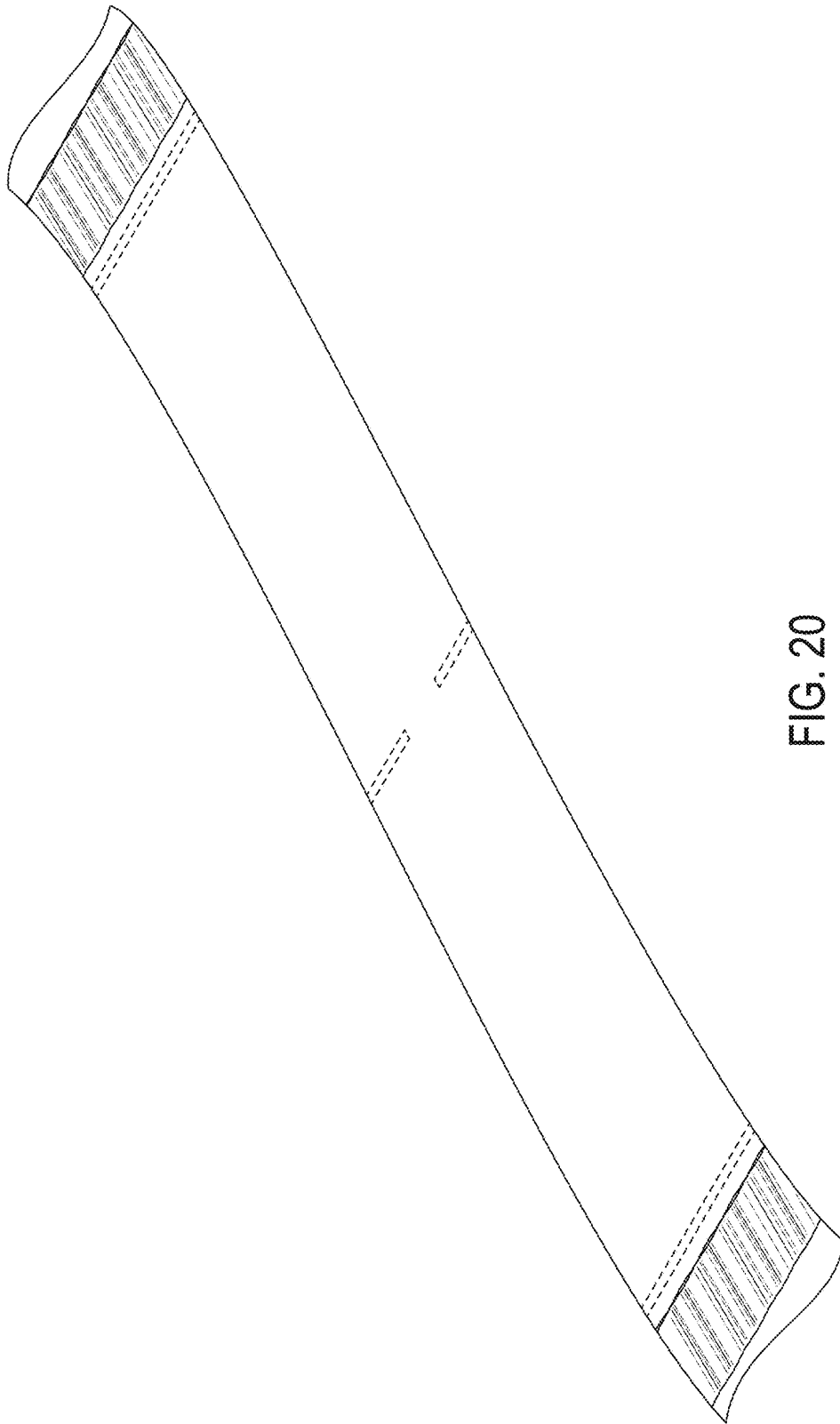

FIG. 20

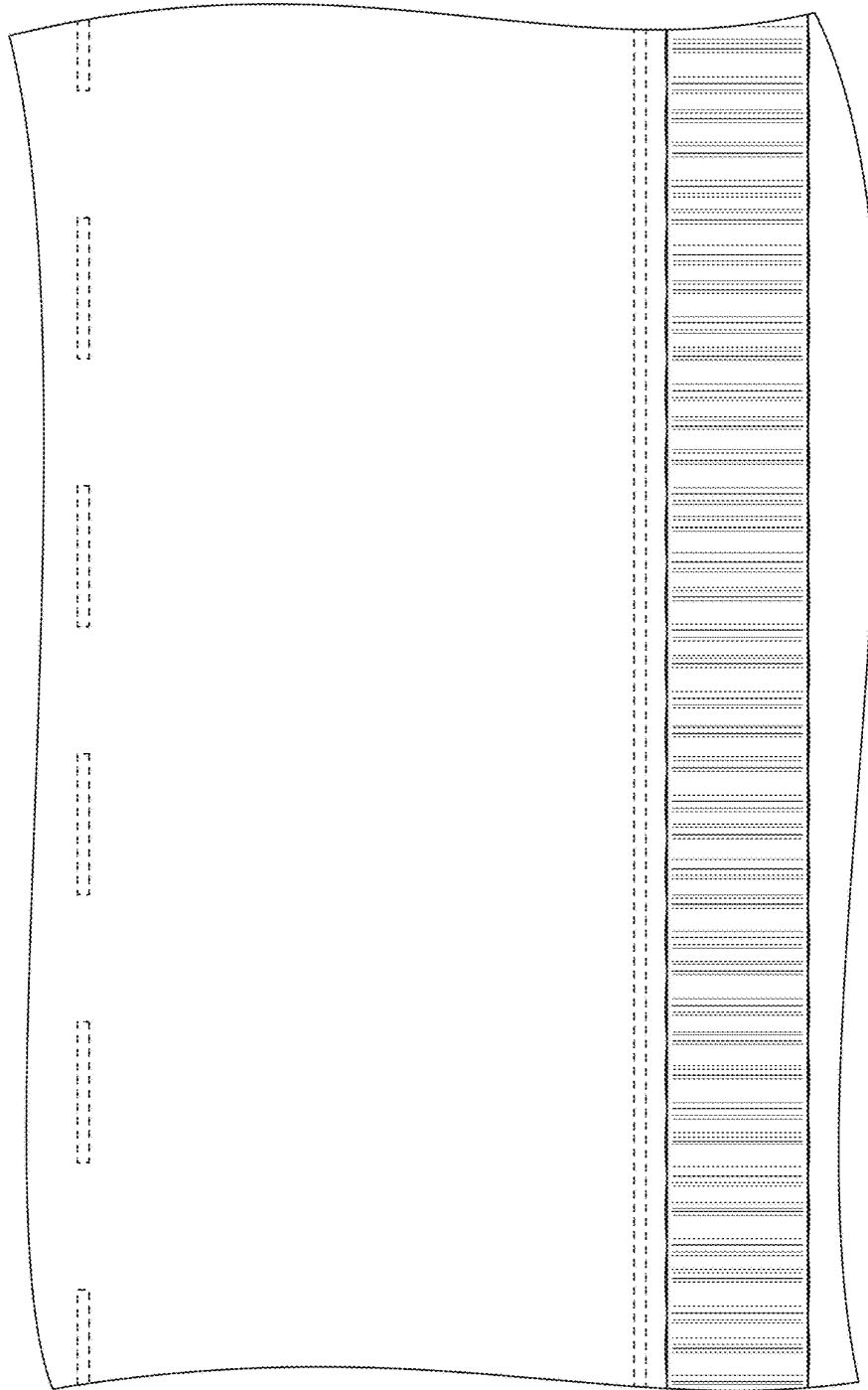

FIG. 21

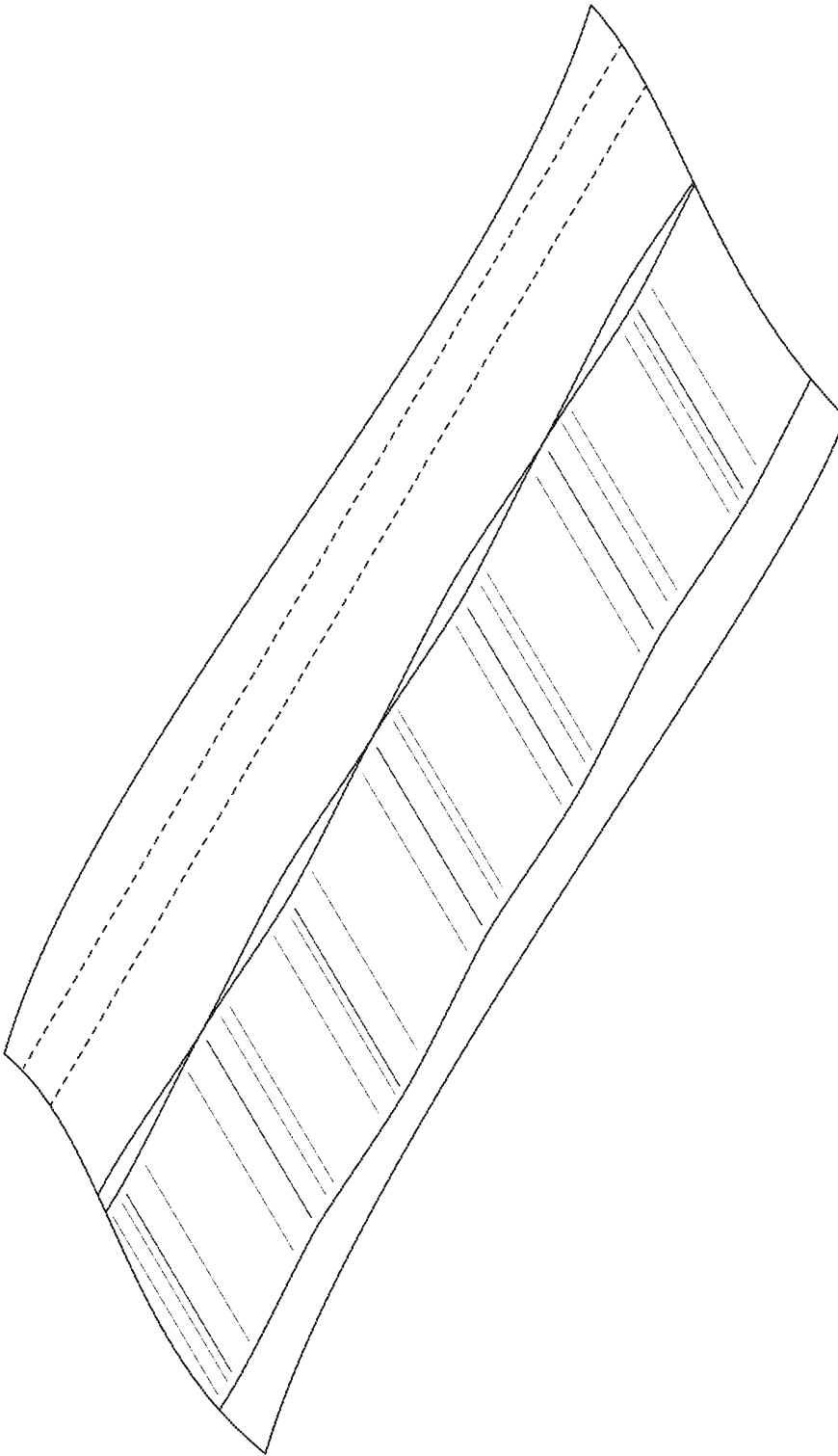

FIG. 22

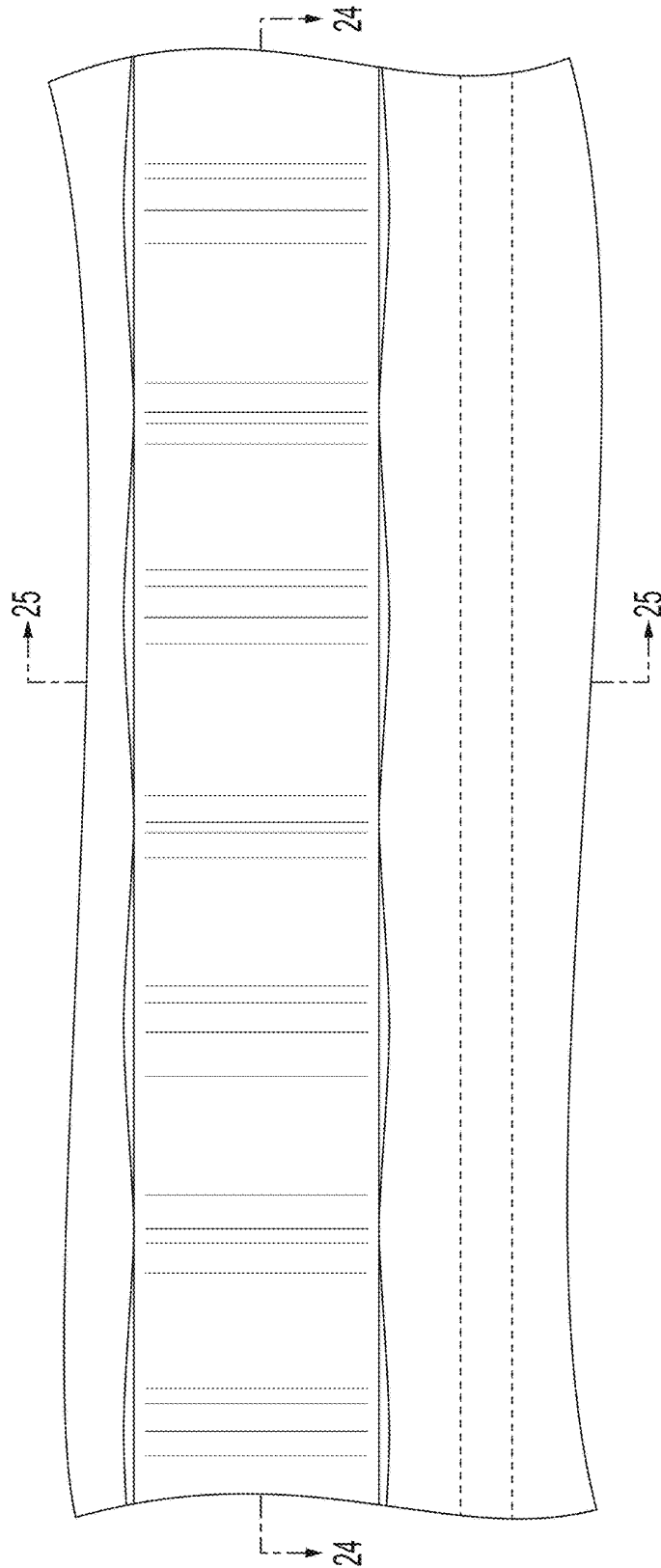

FIG. 23

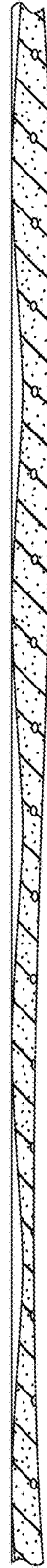

FIG. 24



FIG. 25

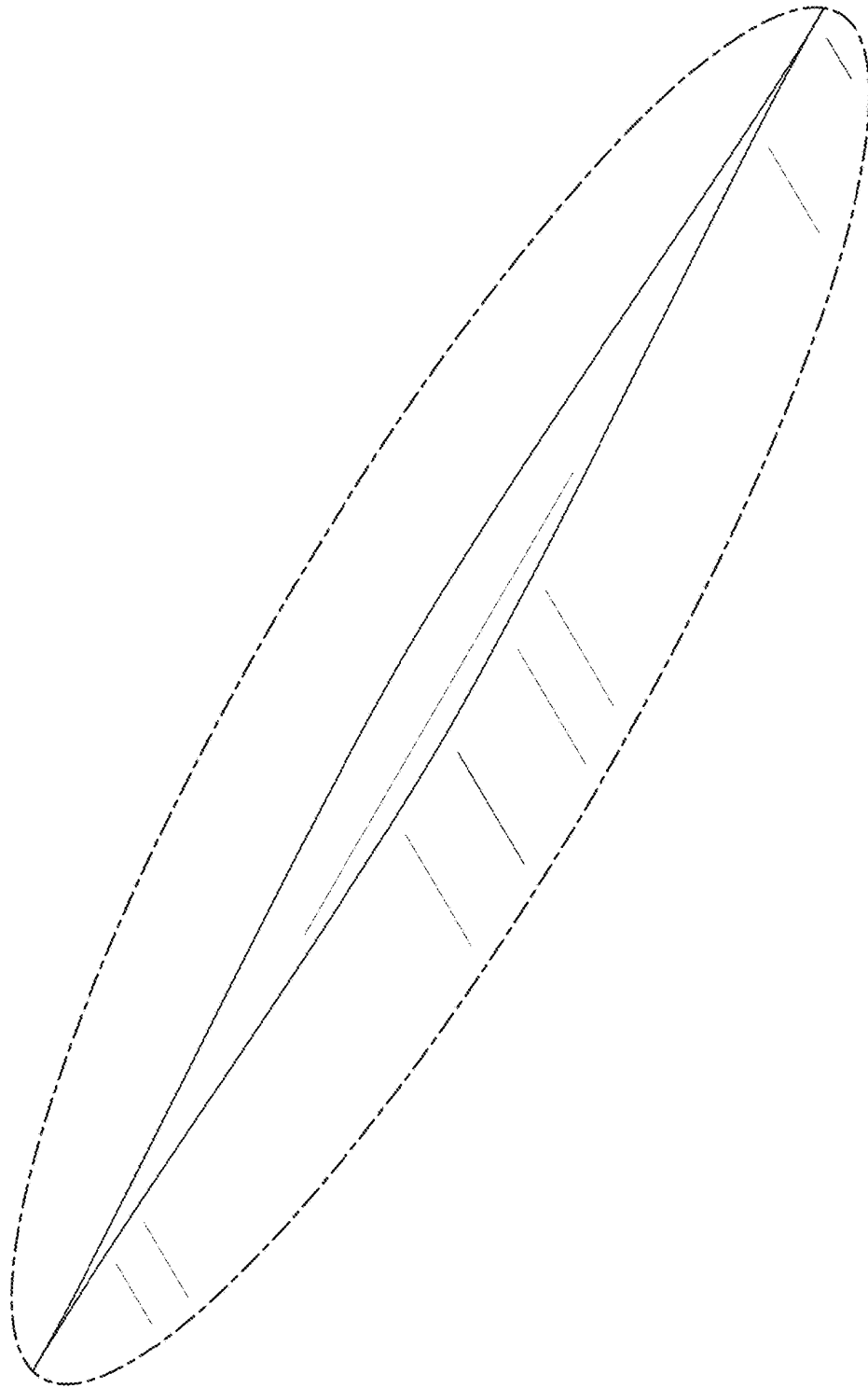

FIG. 26

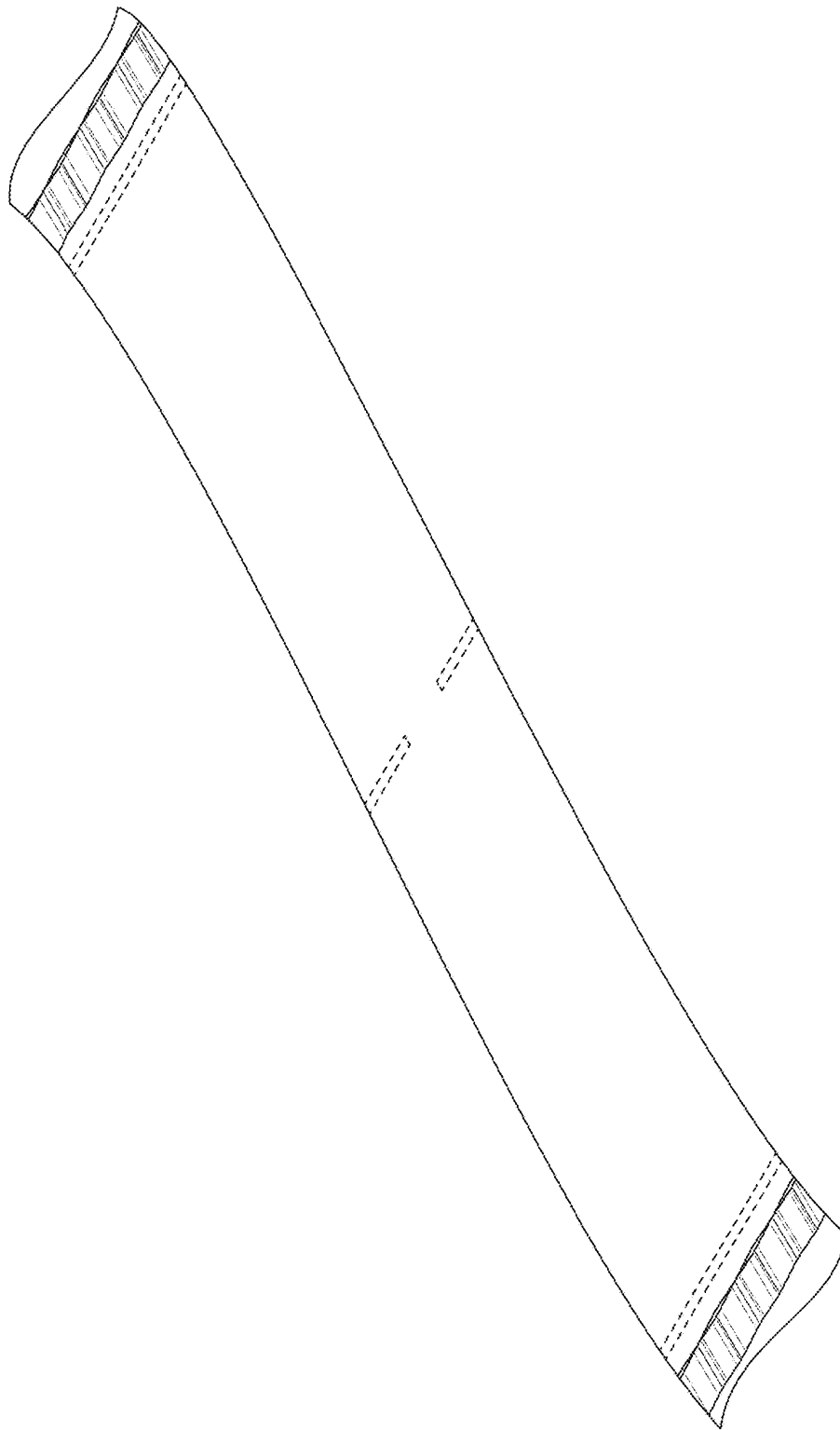

FIG. 27

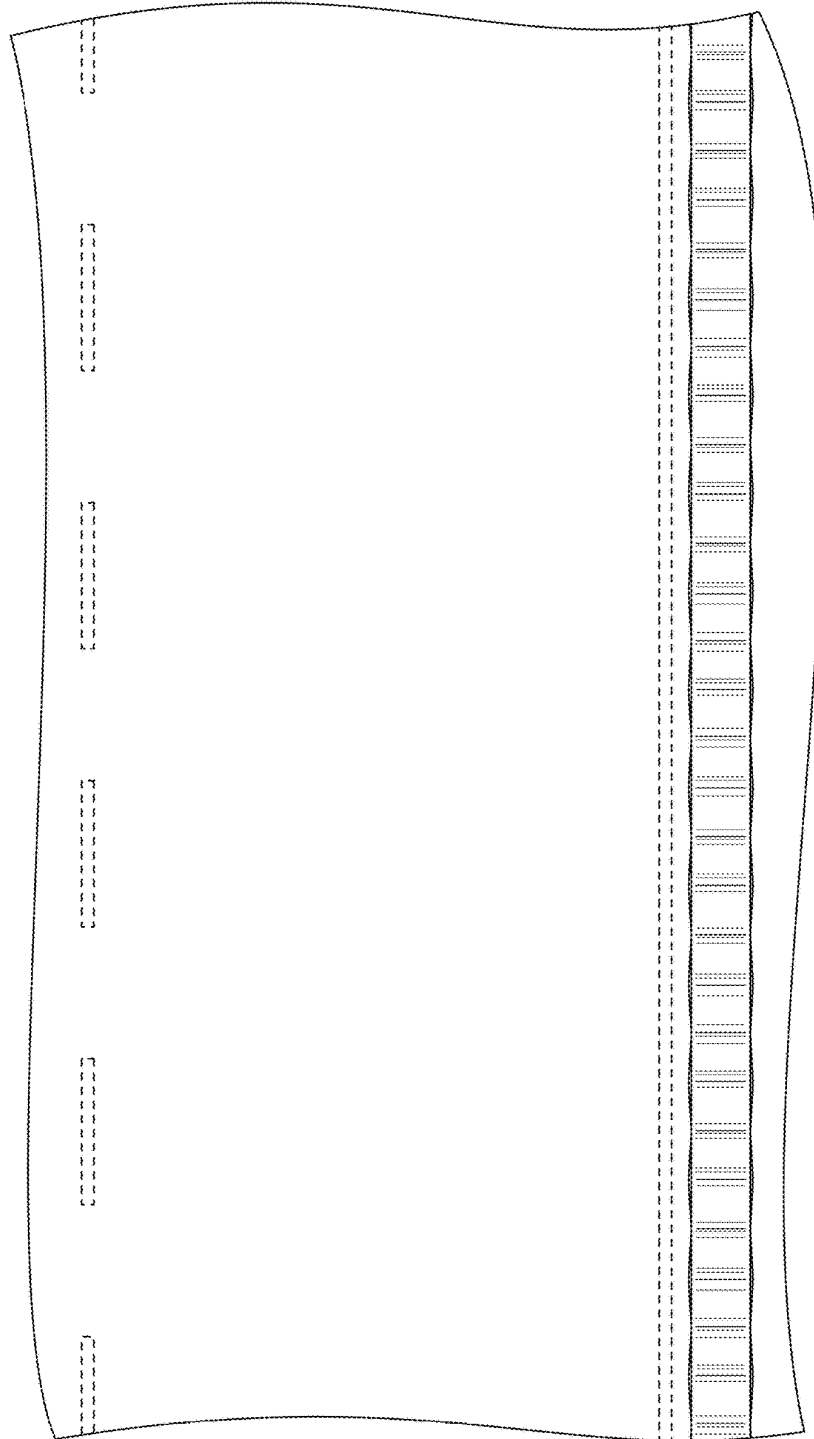

FIG. 28

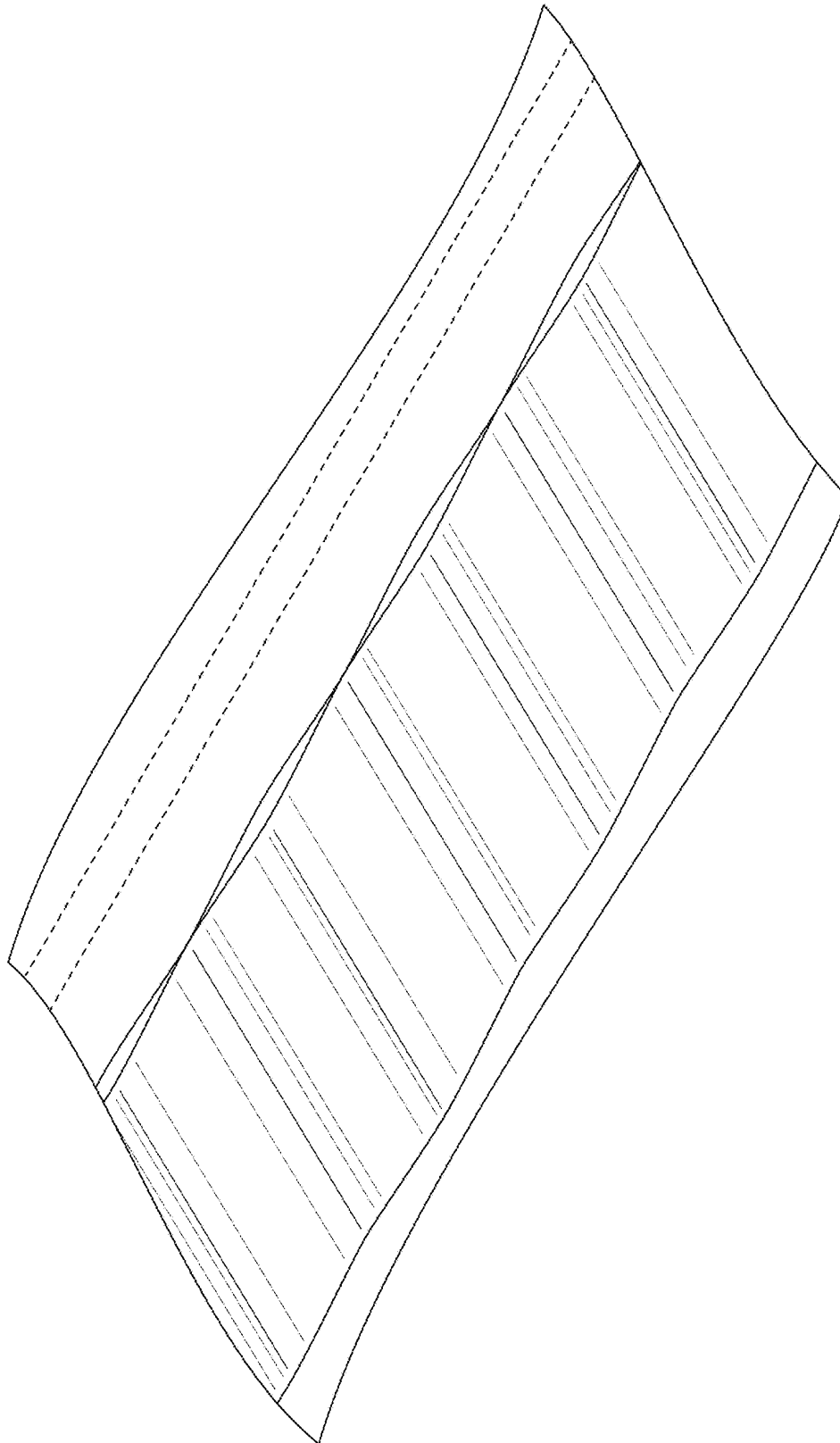

FIG. 29

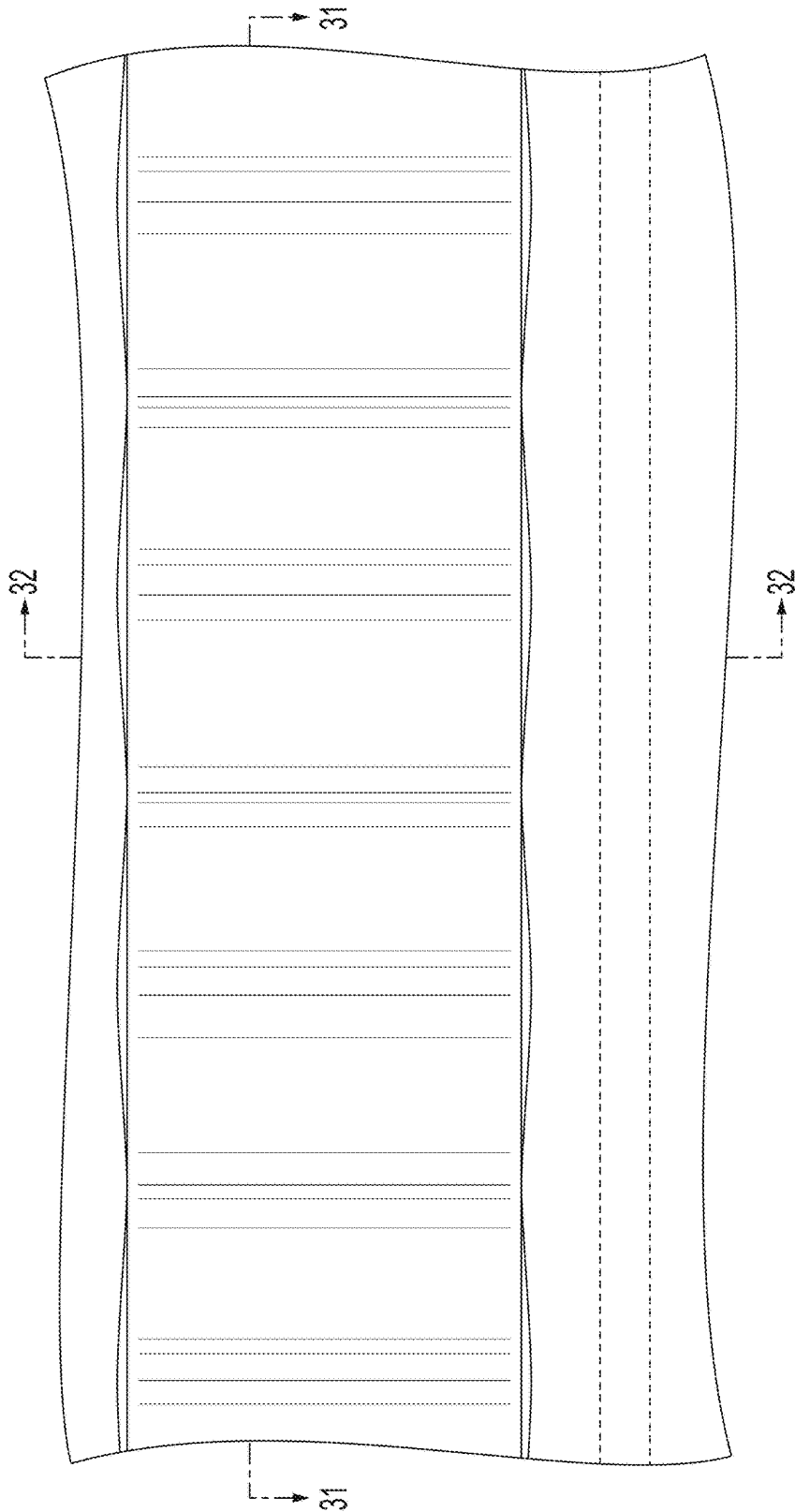

FIG. 30

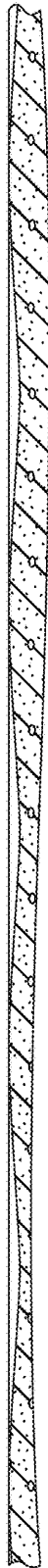

FIG. 31

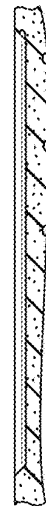

FIG. 32

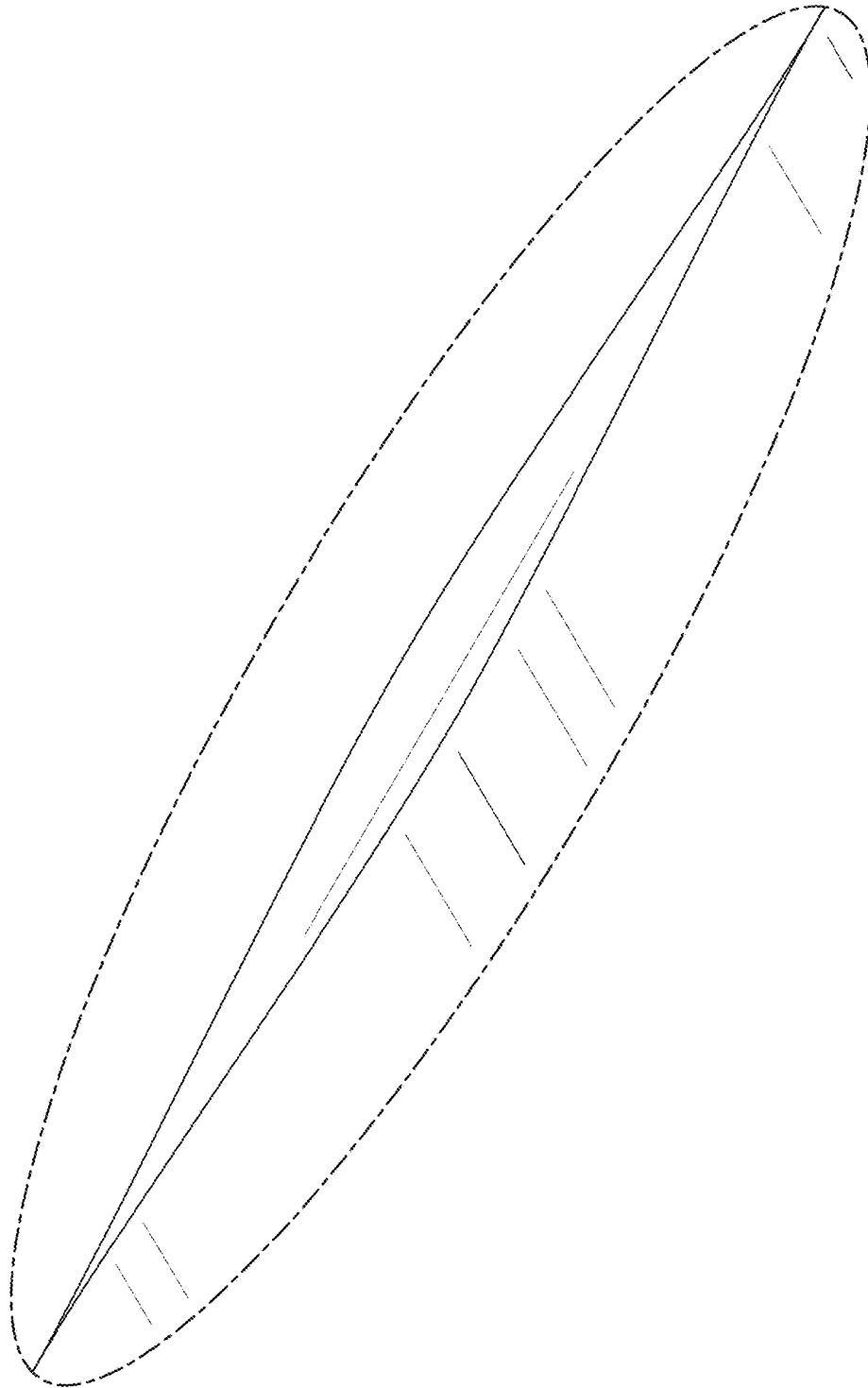

FIG. 33

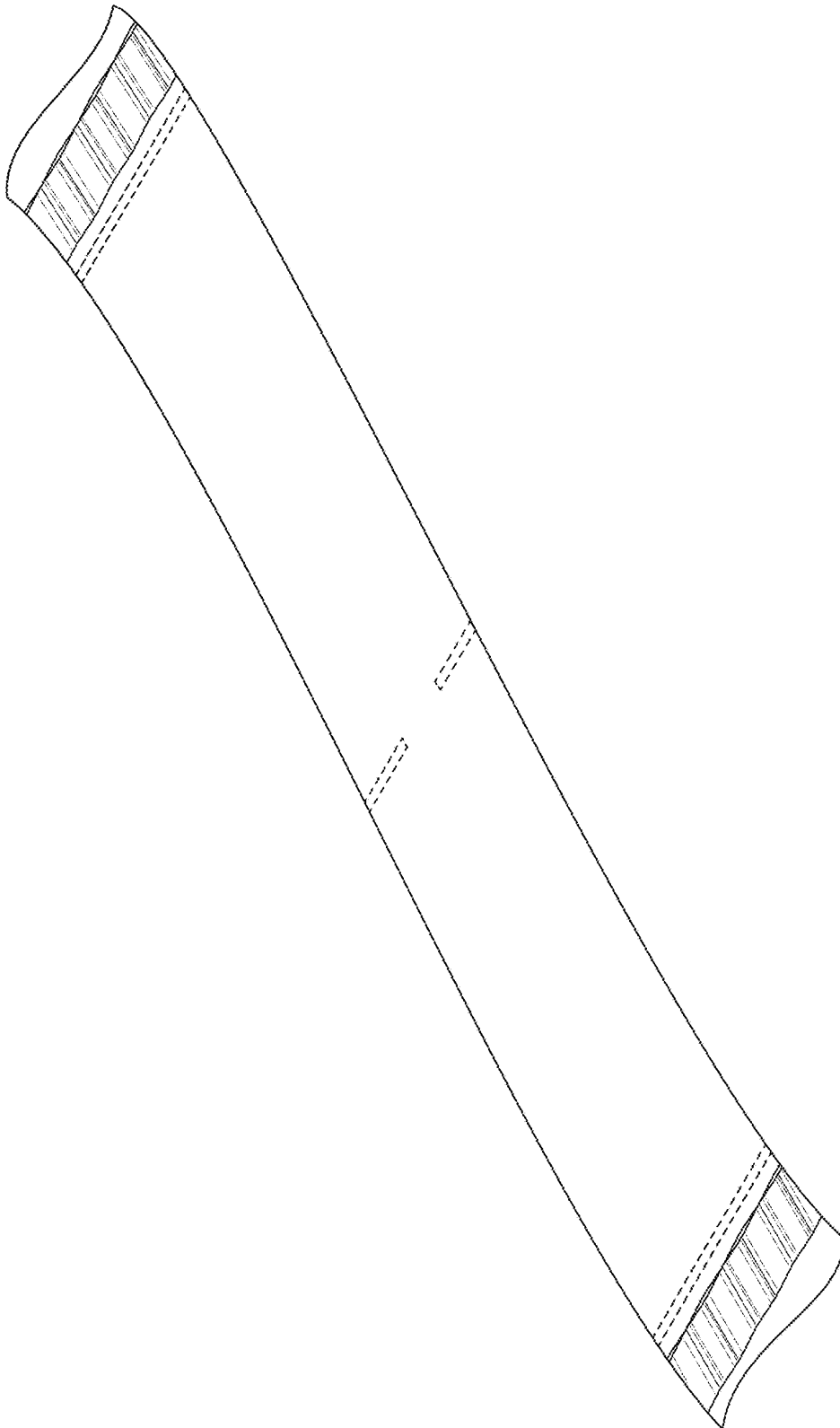

FIG. 34

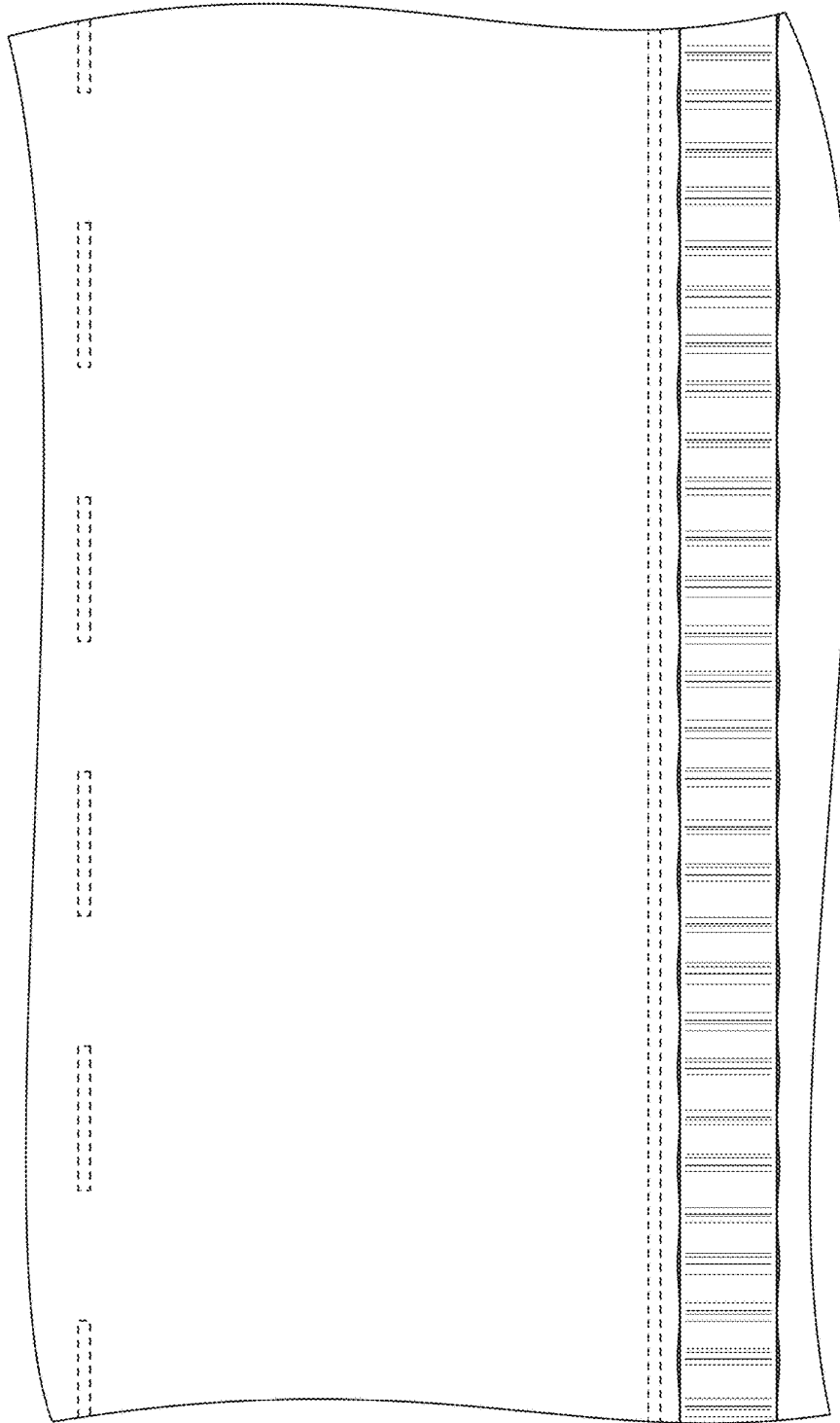

FIG. 35

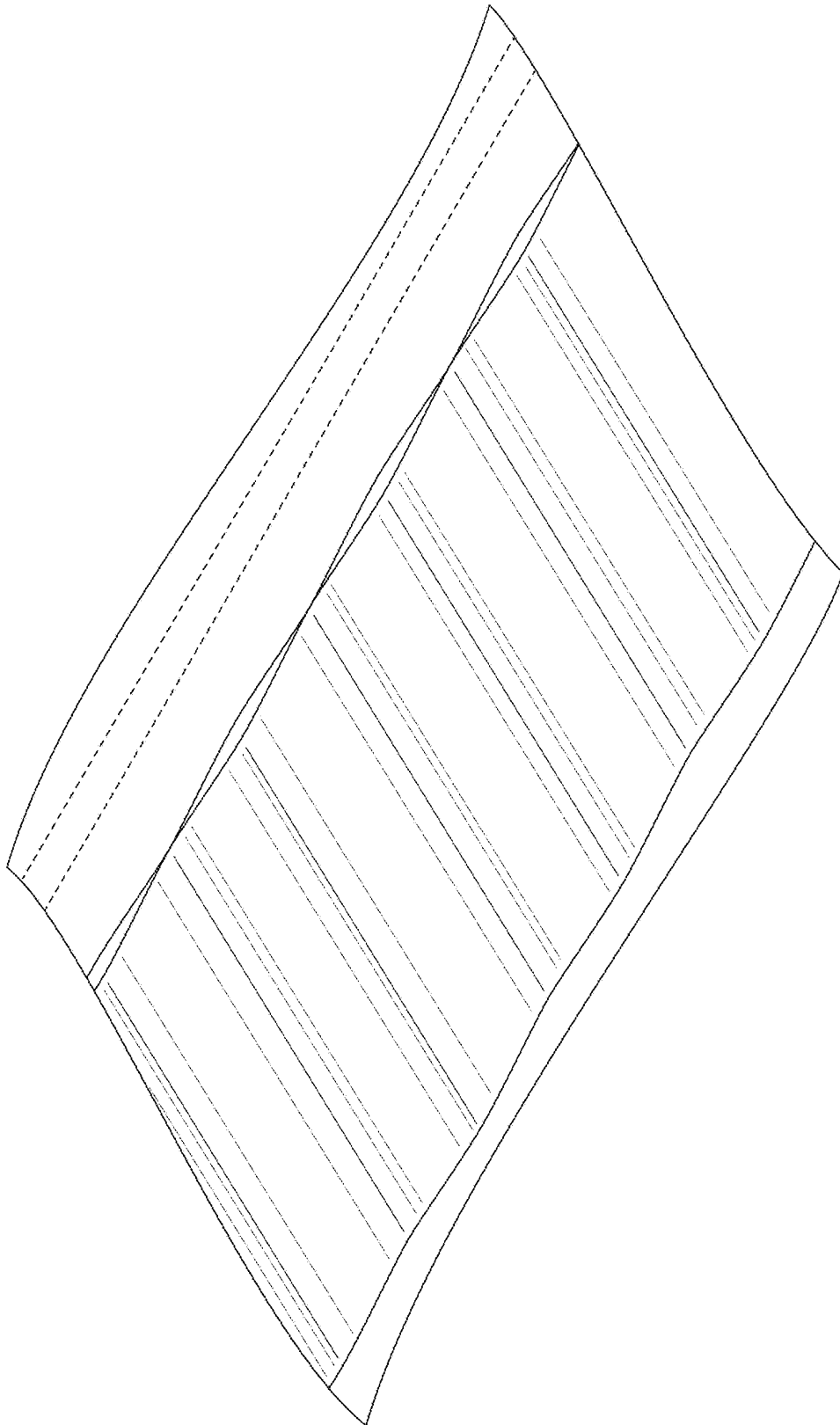

FIG. 36

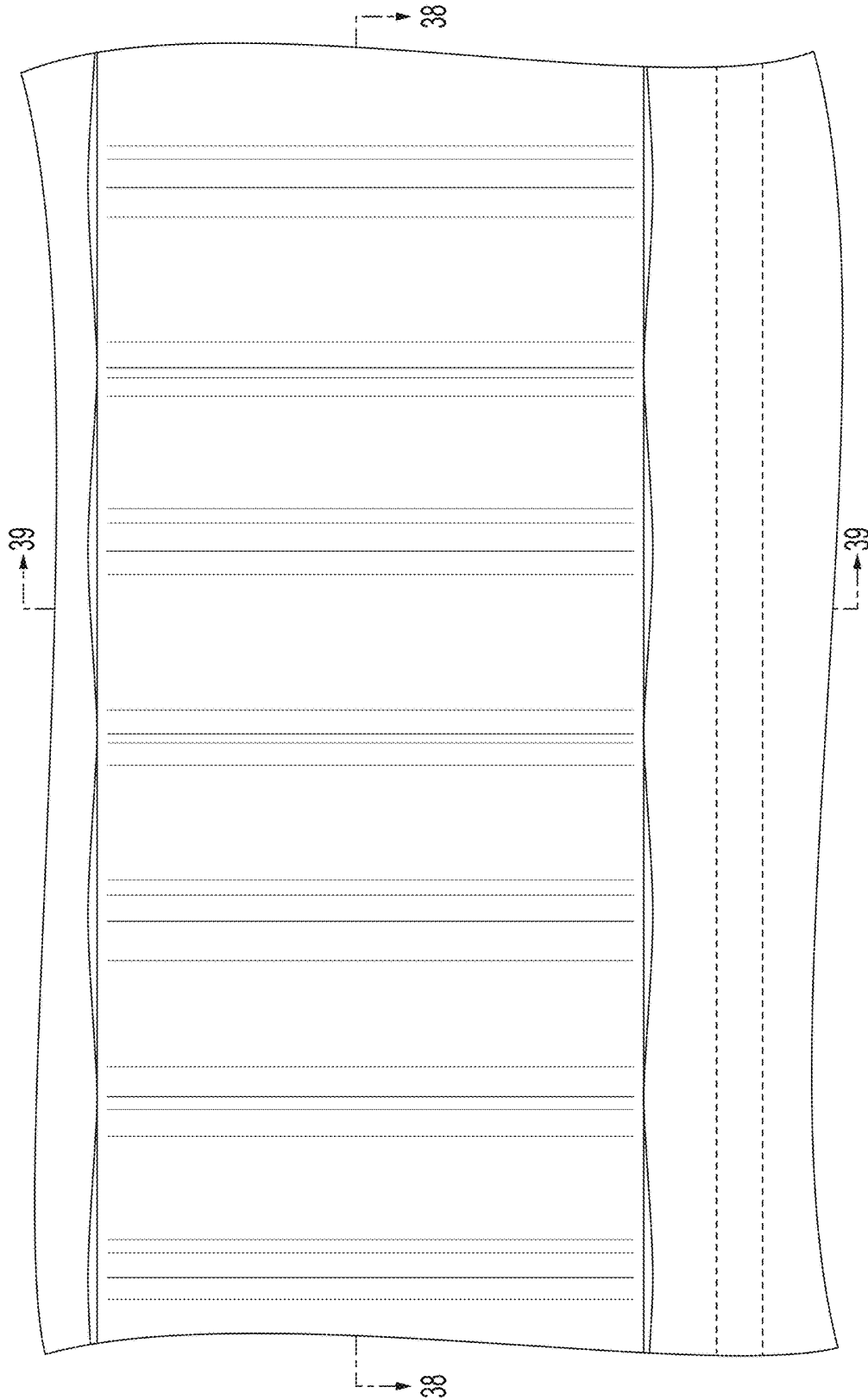

FIG. 37



FIG. 38

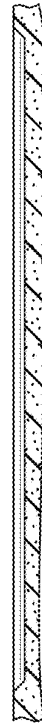

FIG. 39

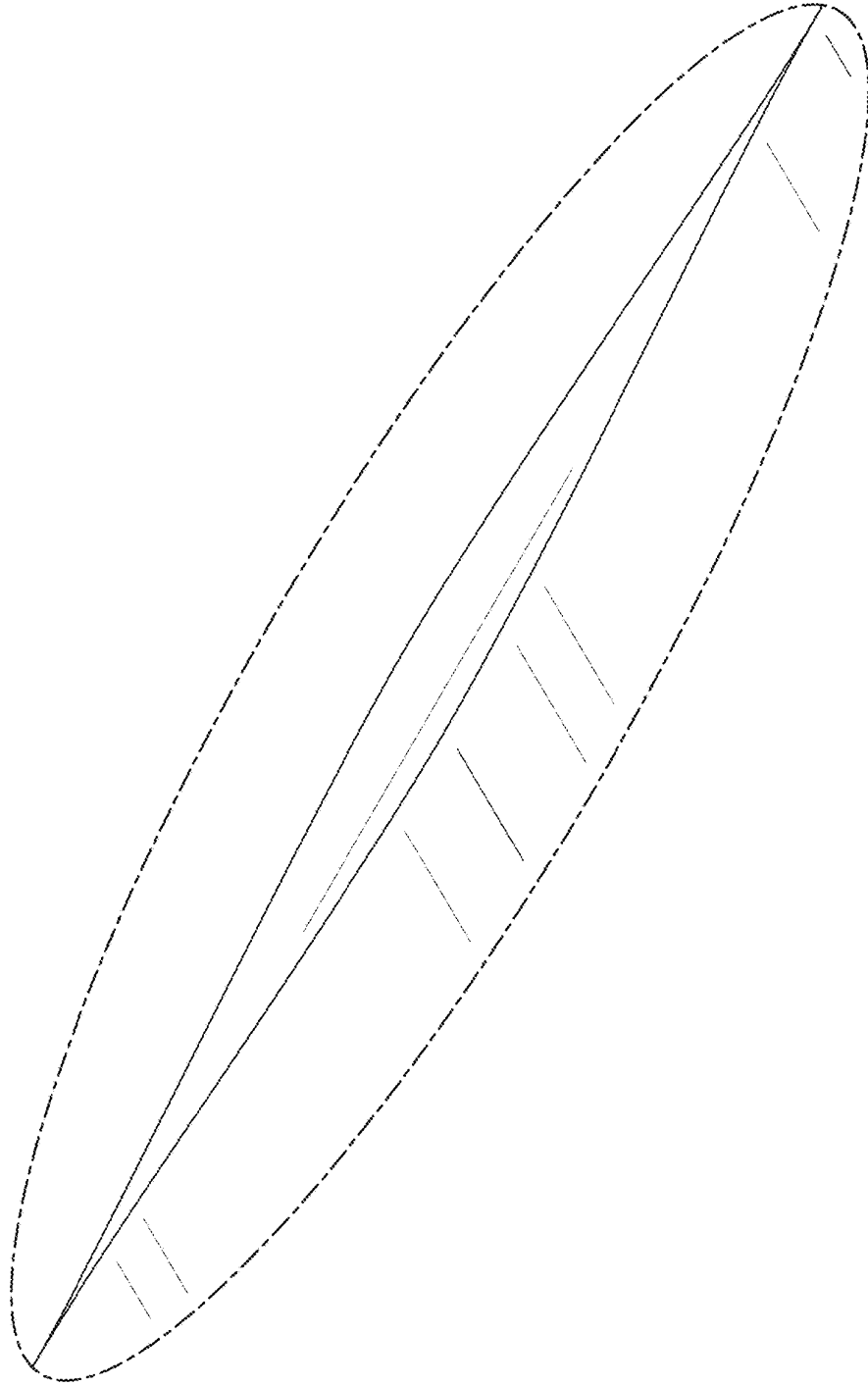

FIG. 40

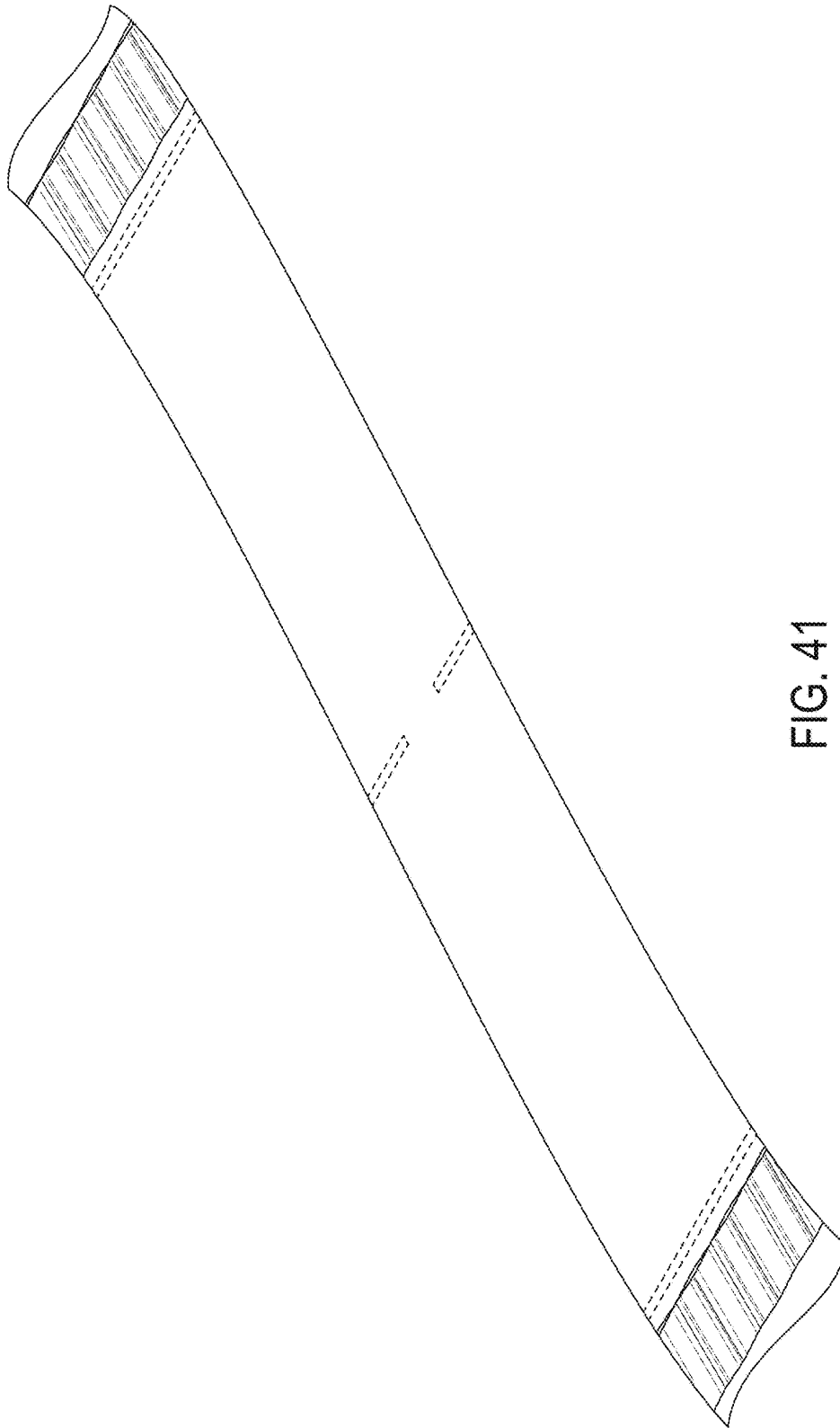

FIG. 41

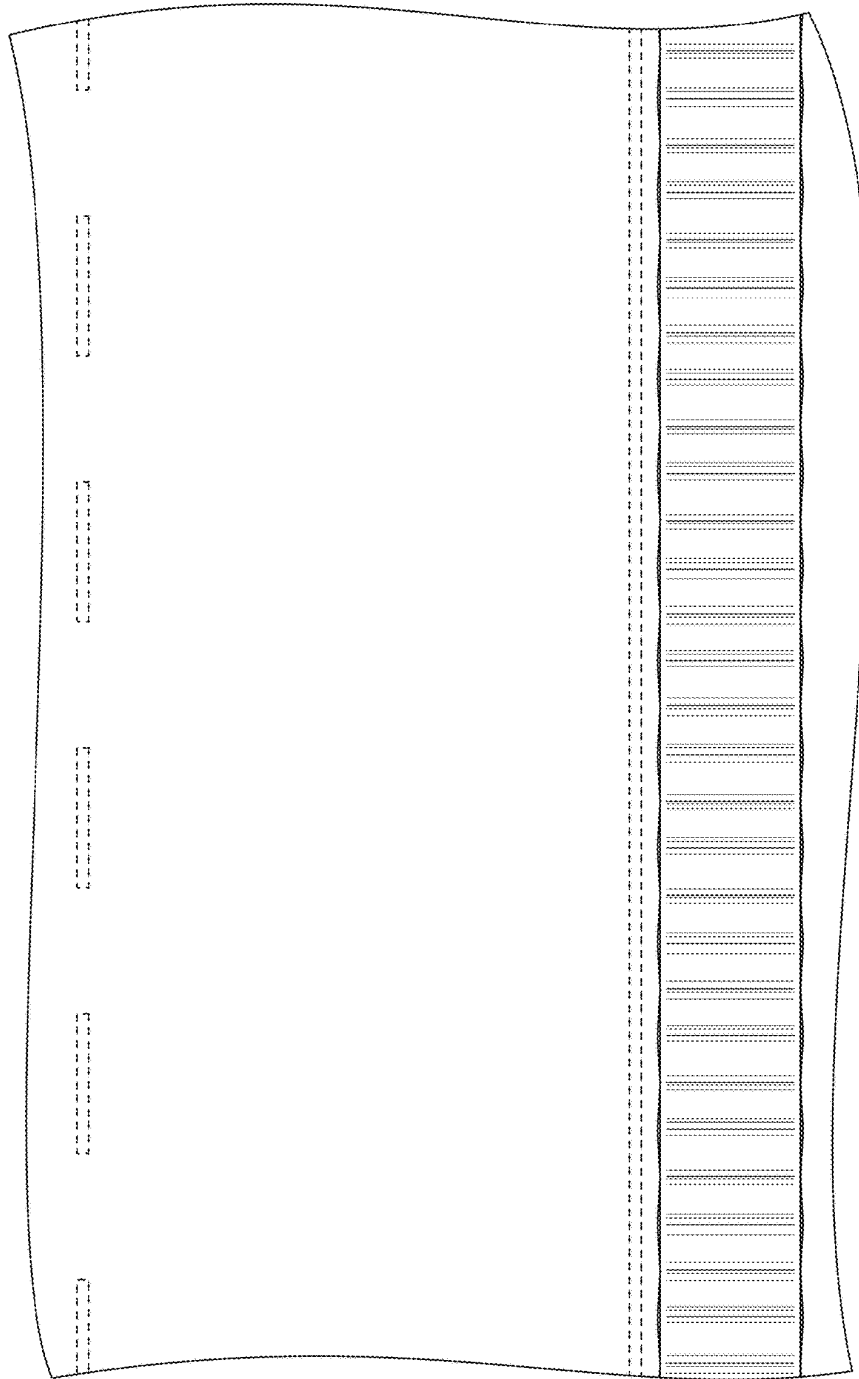

FIG. 42

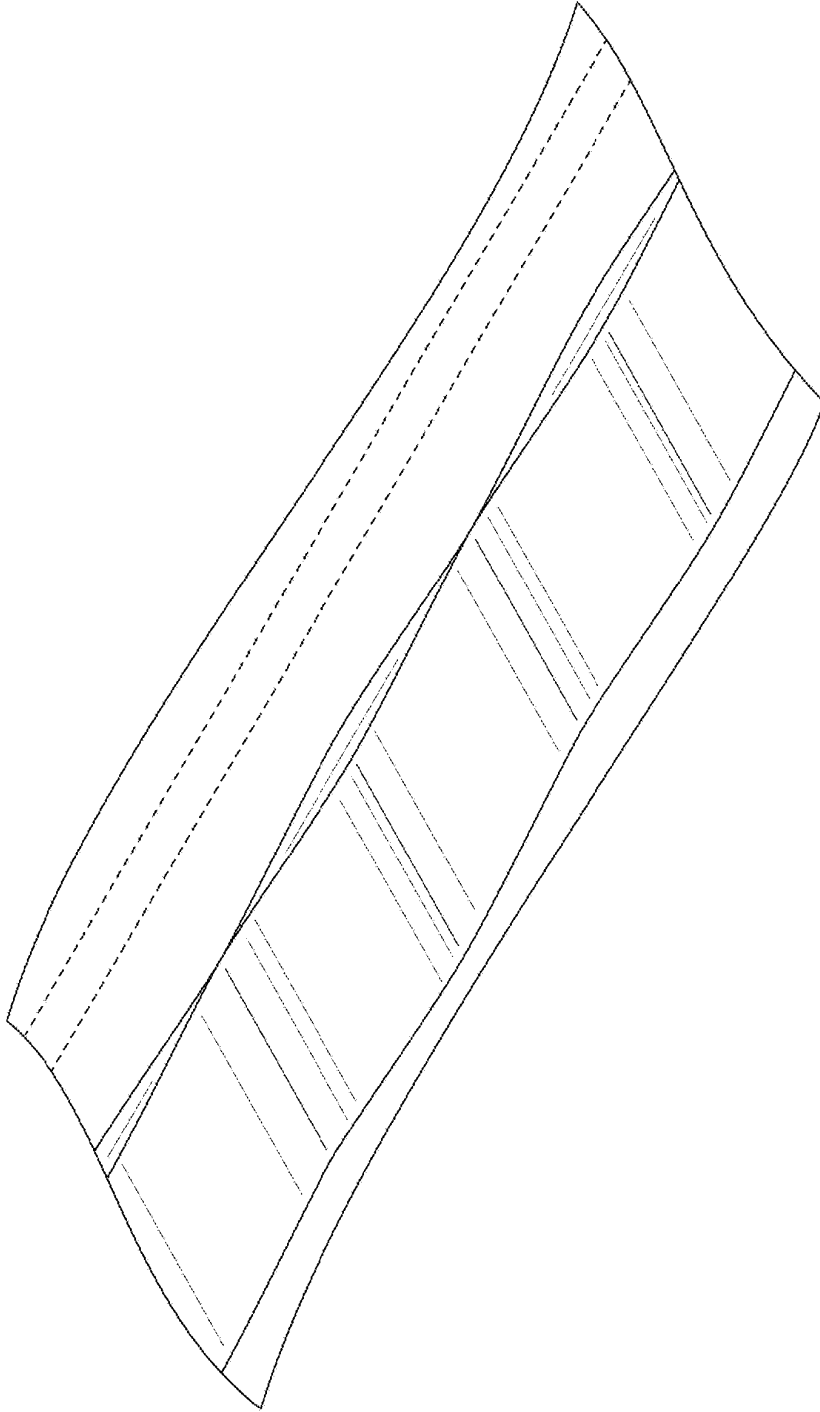

FIG. 43

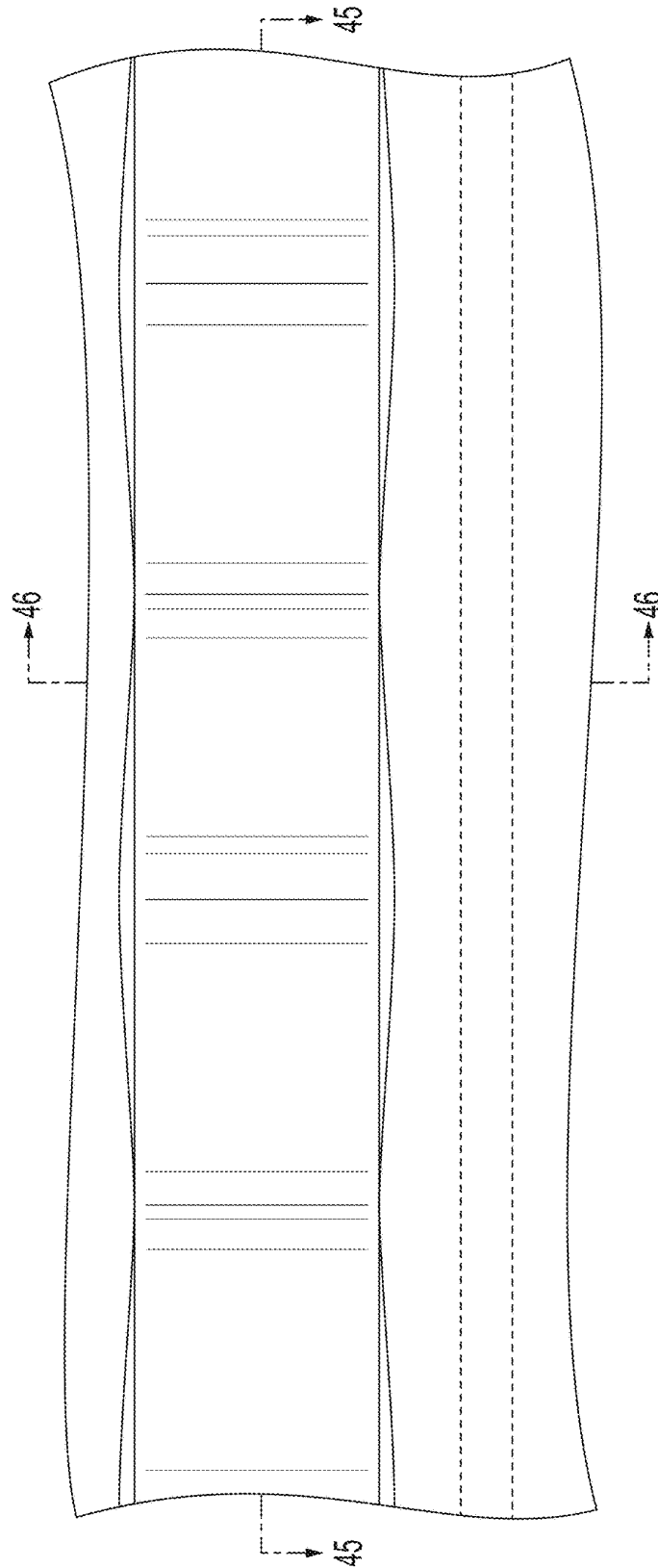

FIG. 44

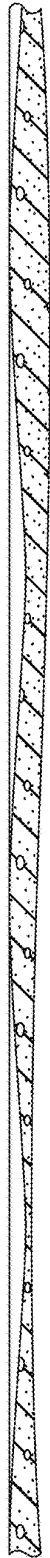

FIG. 45

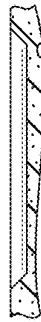

FIG. 46

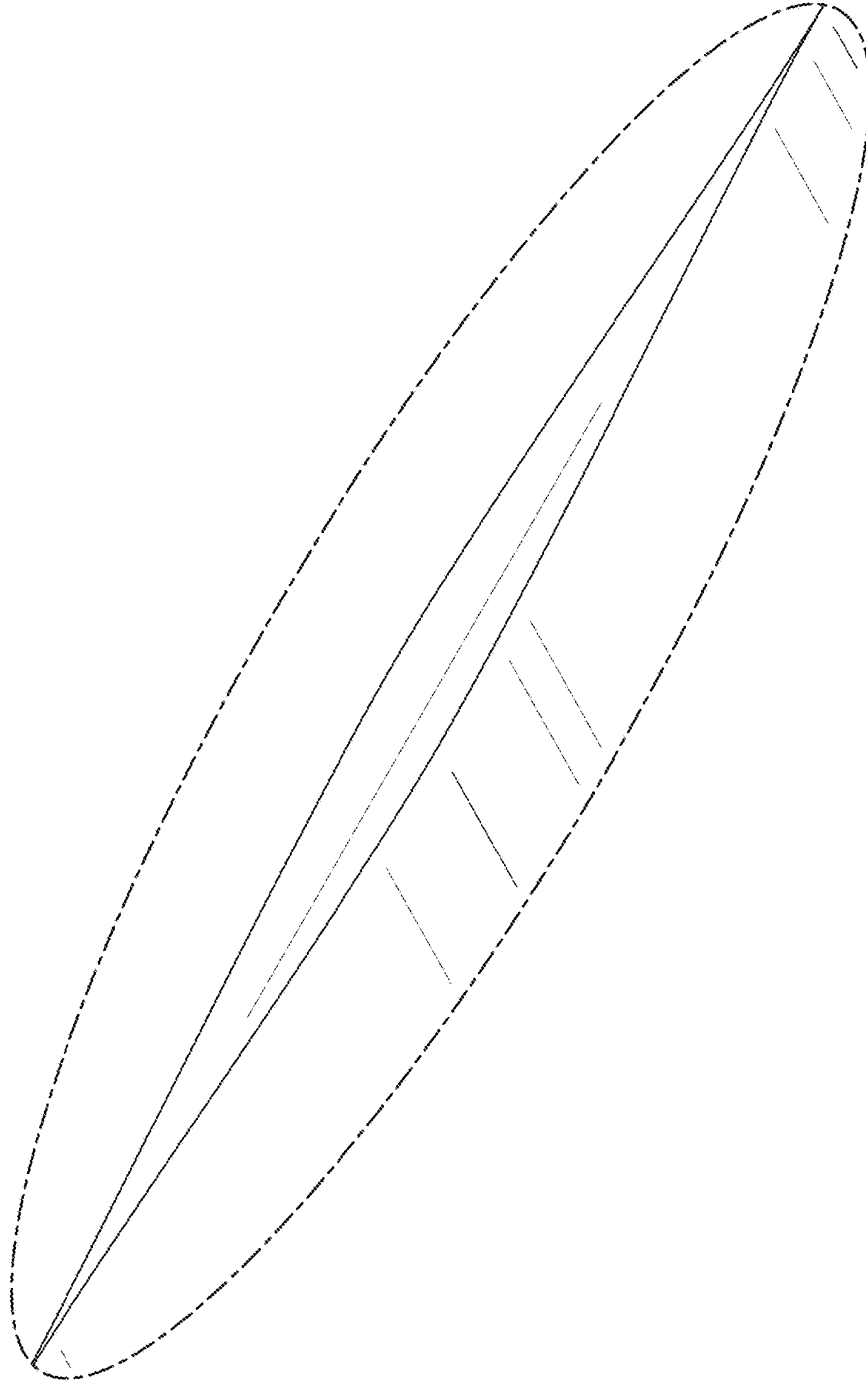

FIG. 47

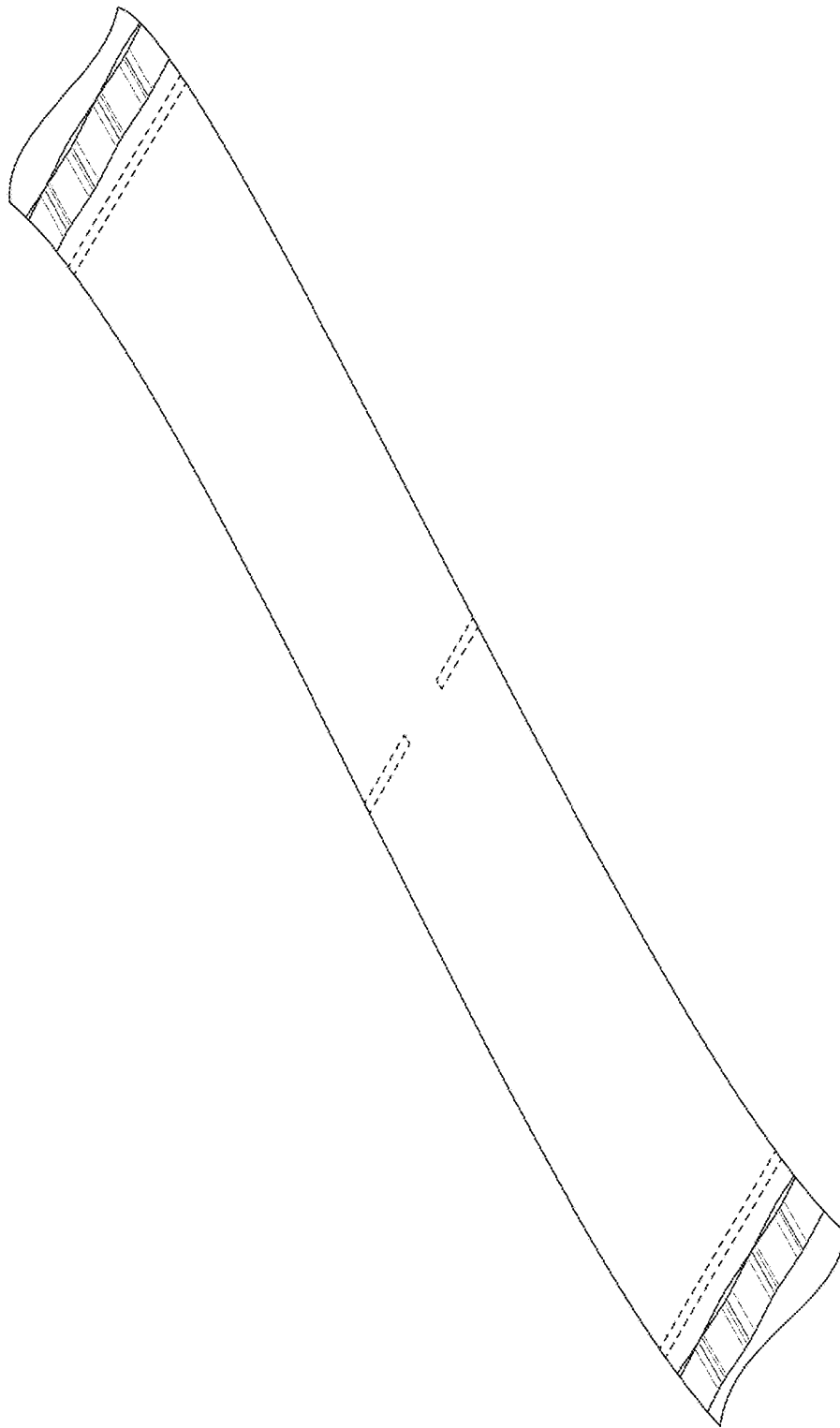

FIG. 48

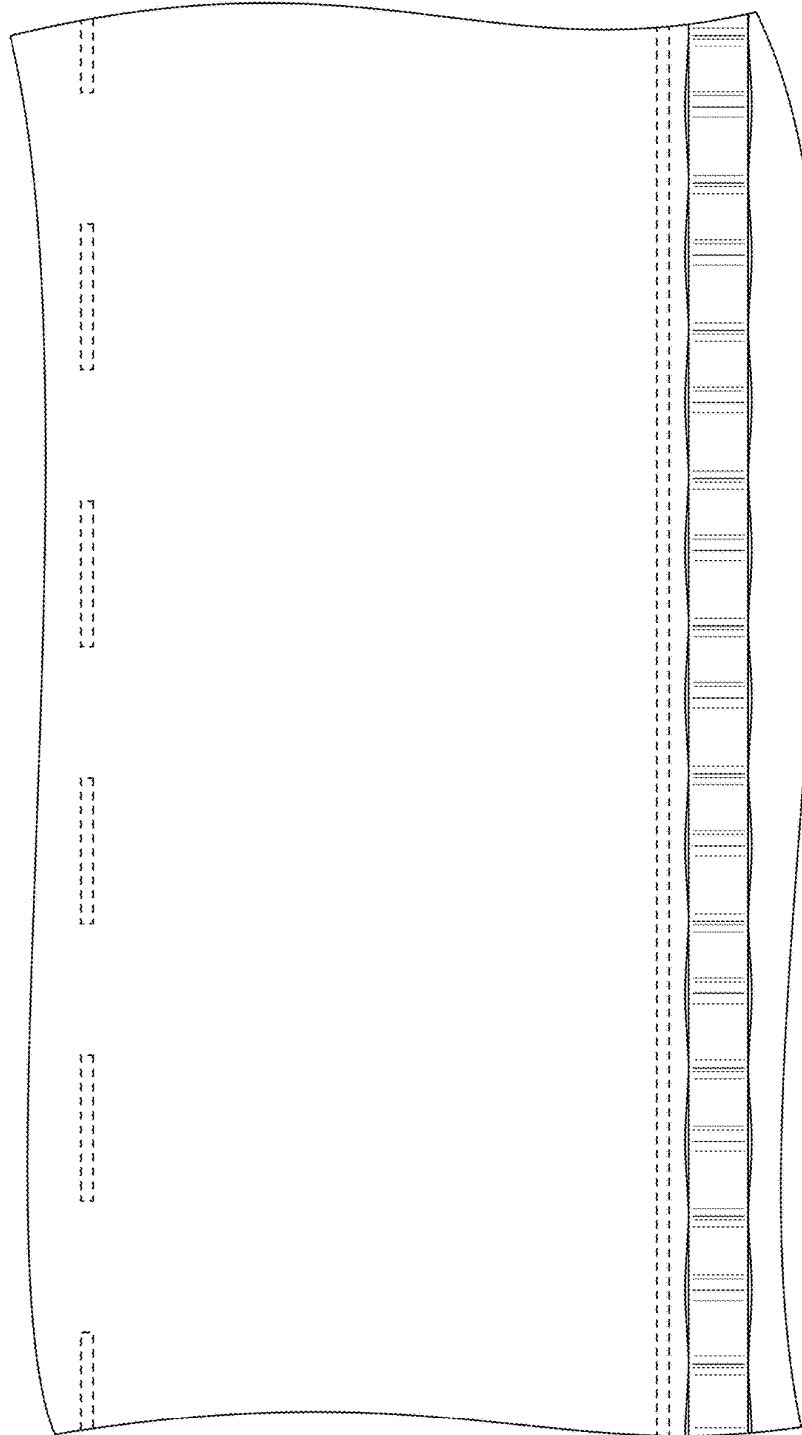

FIG. 49

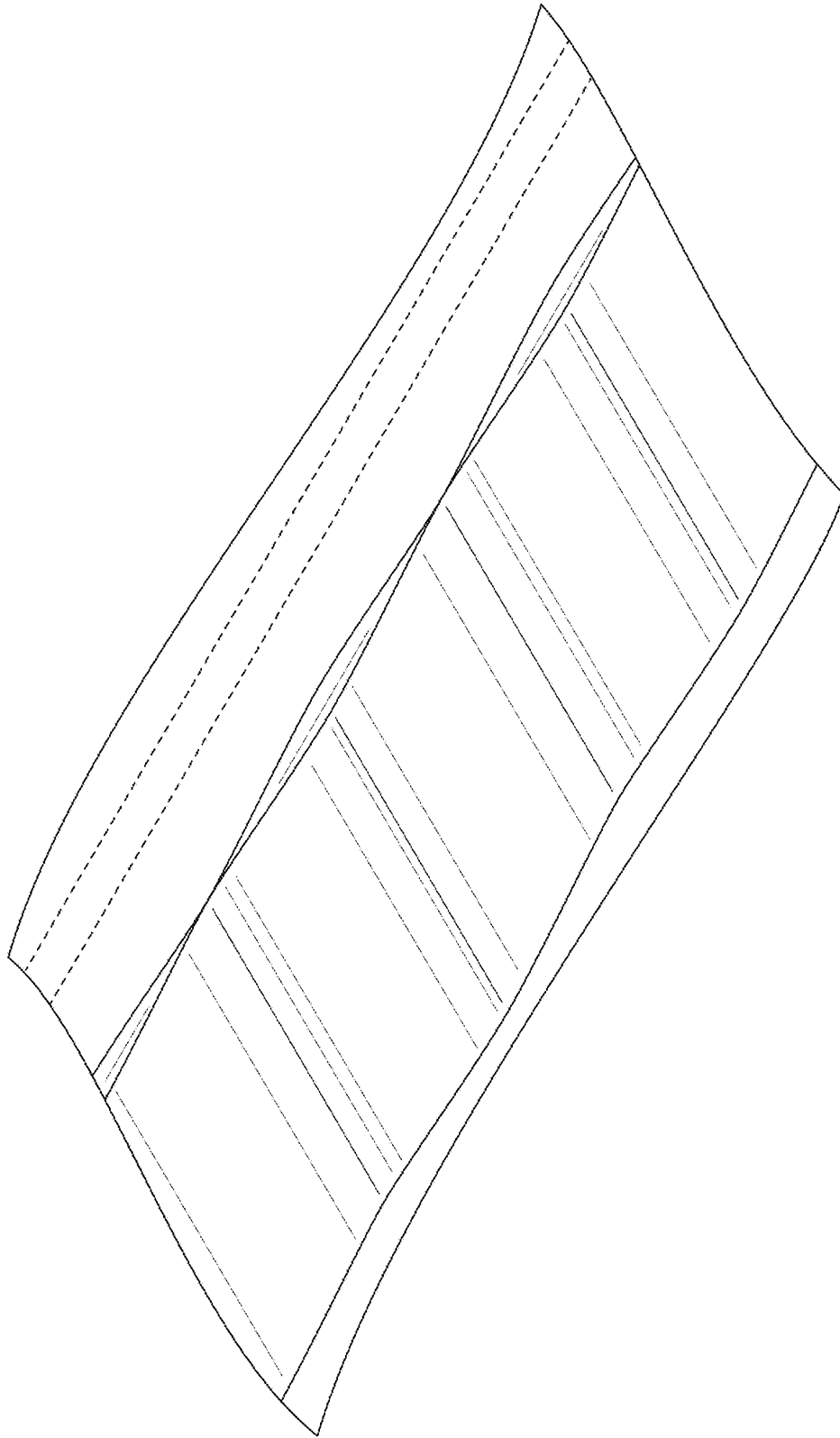

FIG. 50

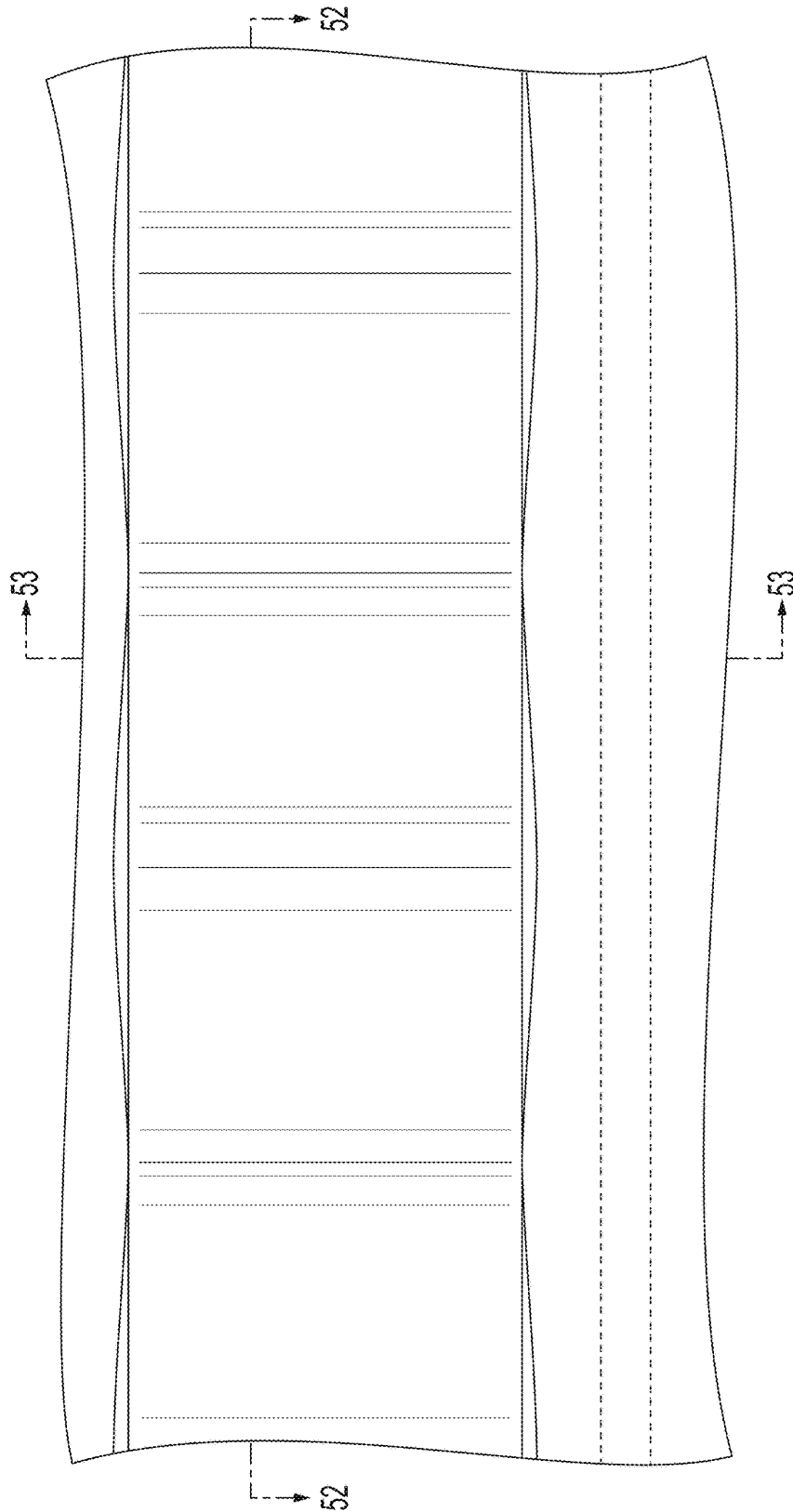

FIG. 51

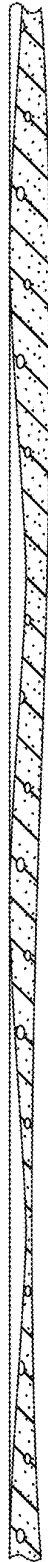

FIG. 52



FIG. 53

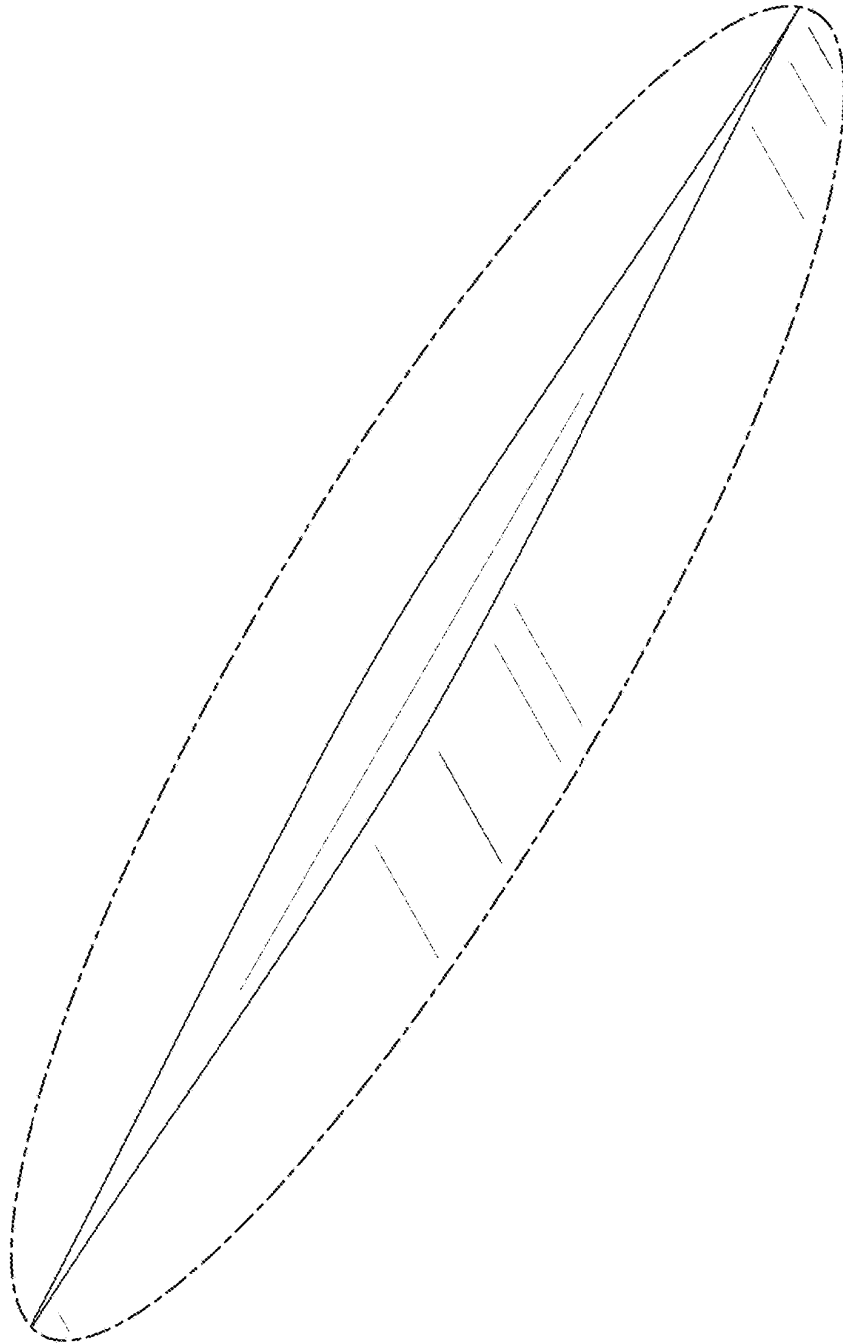

FIG. 54

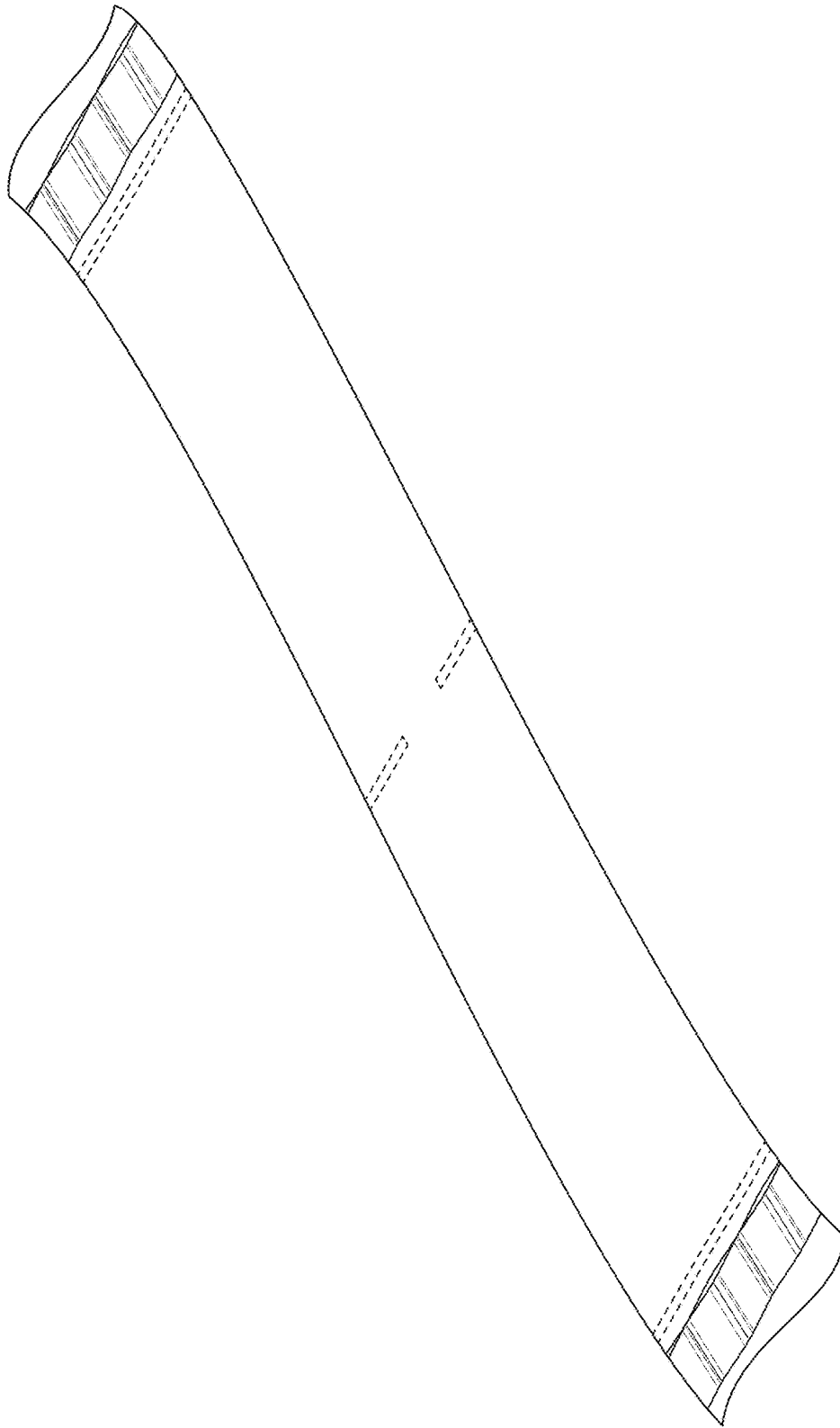

FIG. 55

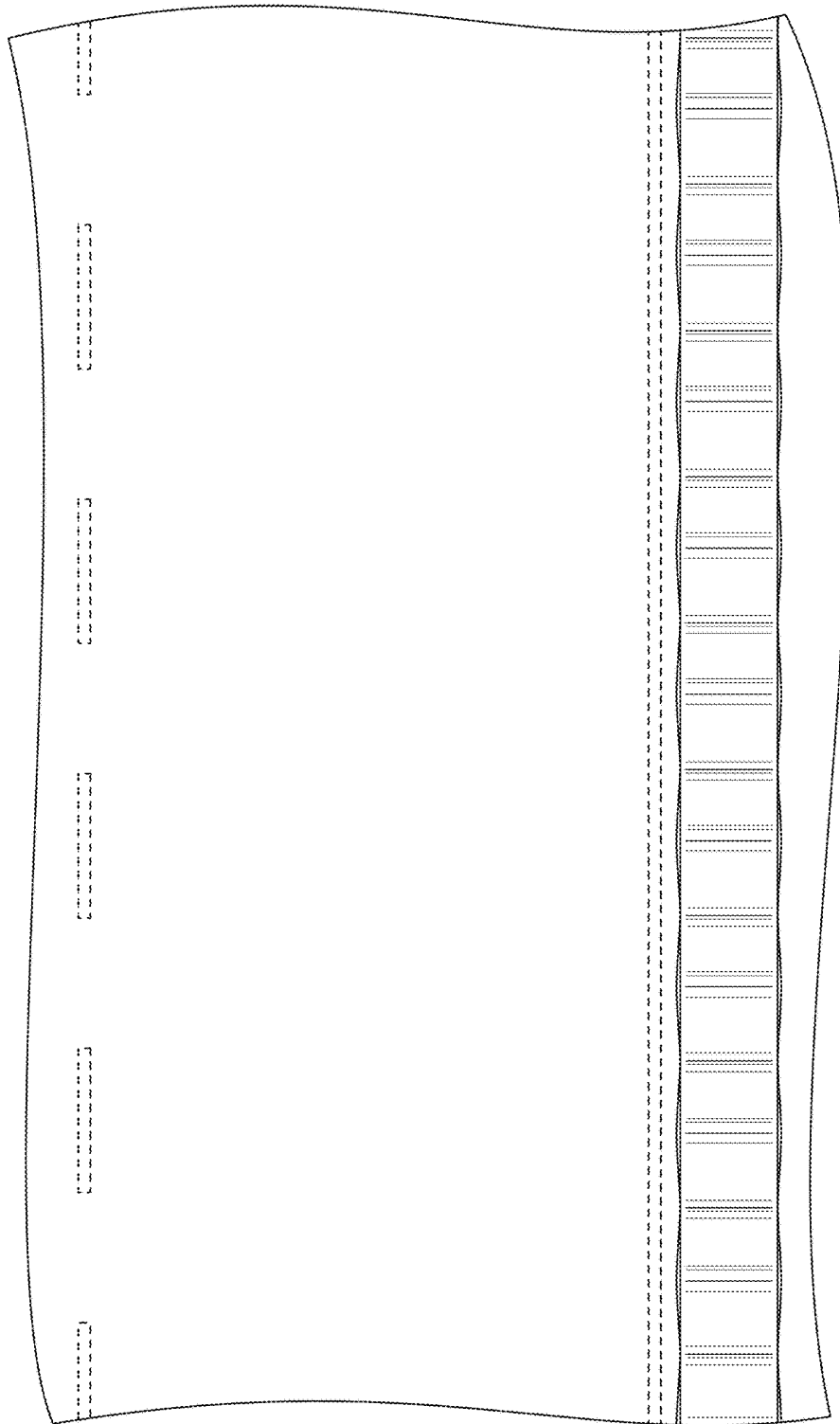

FIG. 56

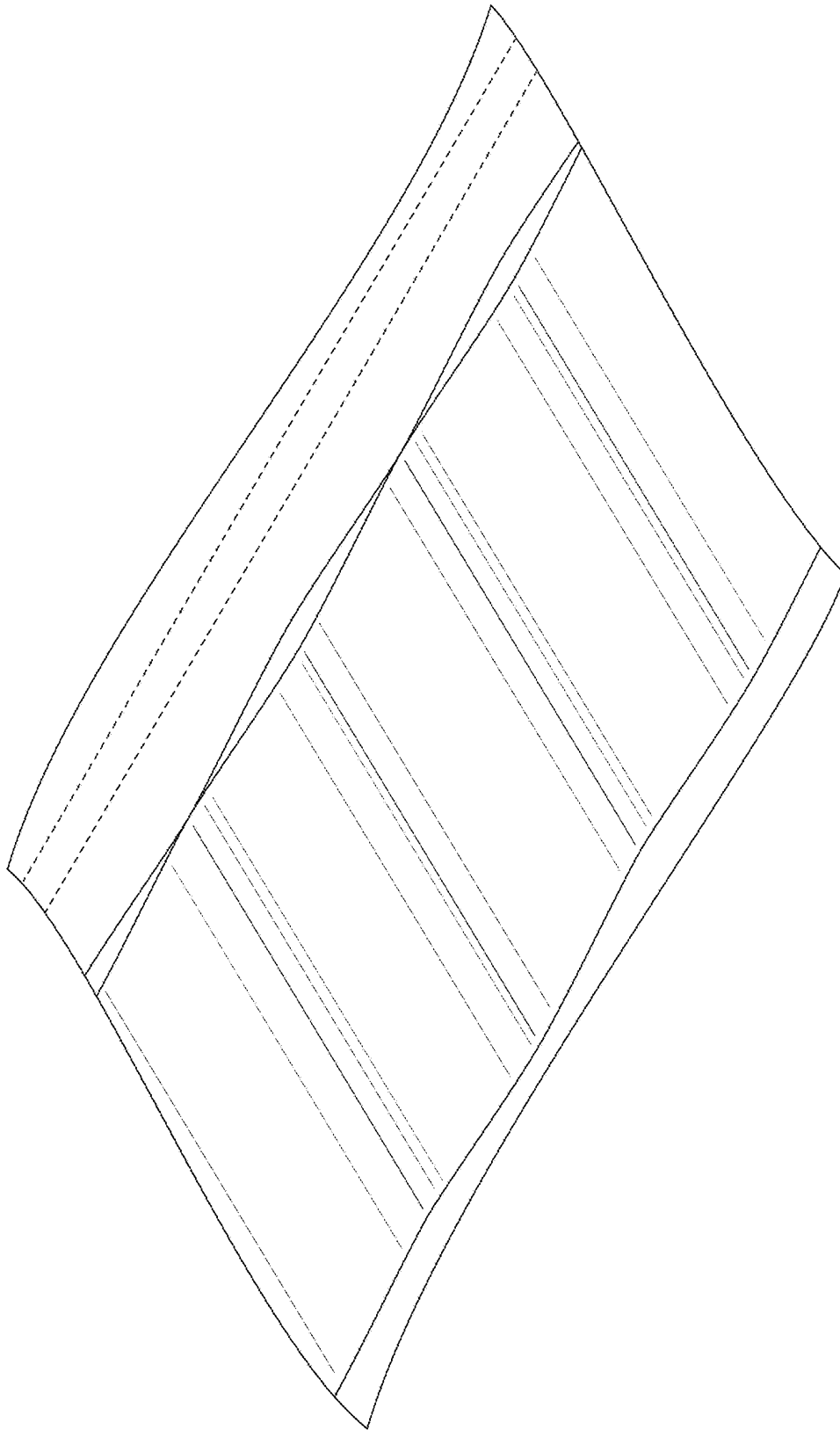

FIG. 57

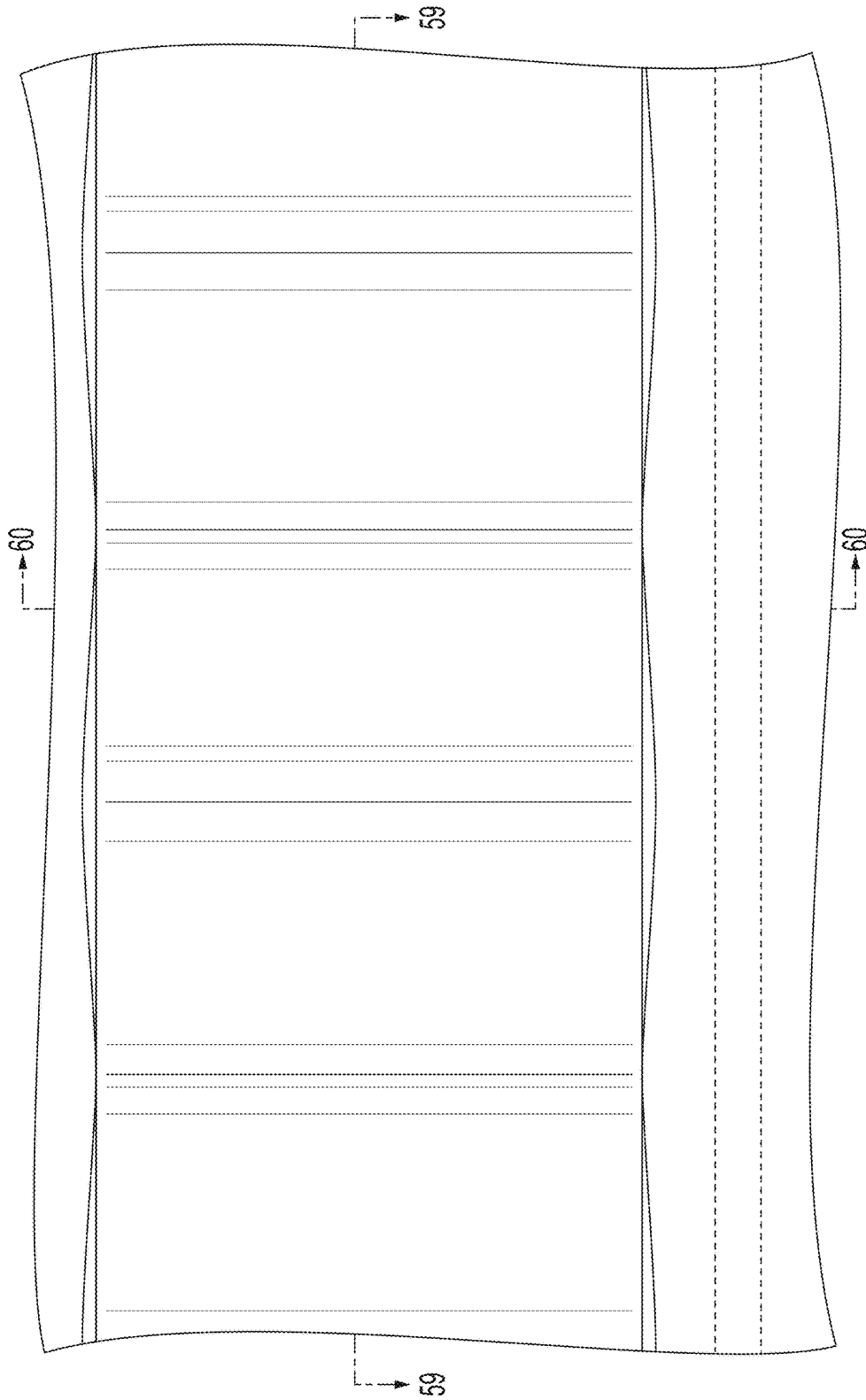

FIG. 58



FIG. 59

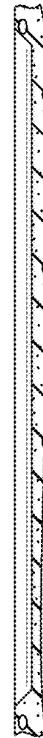

FIG. 60

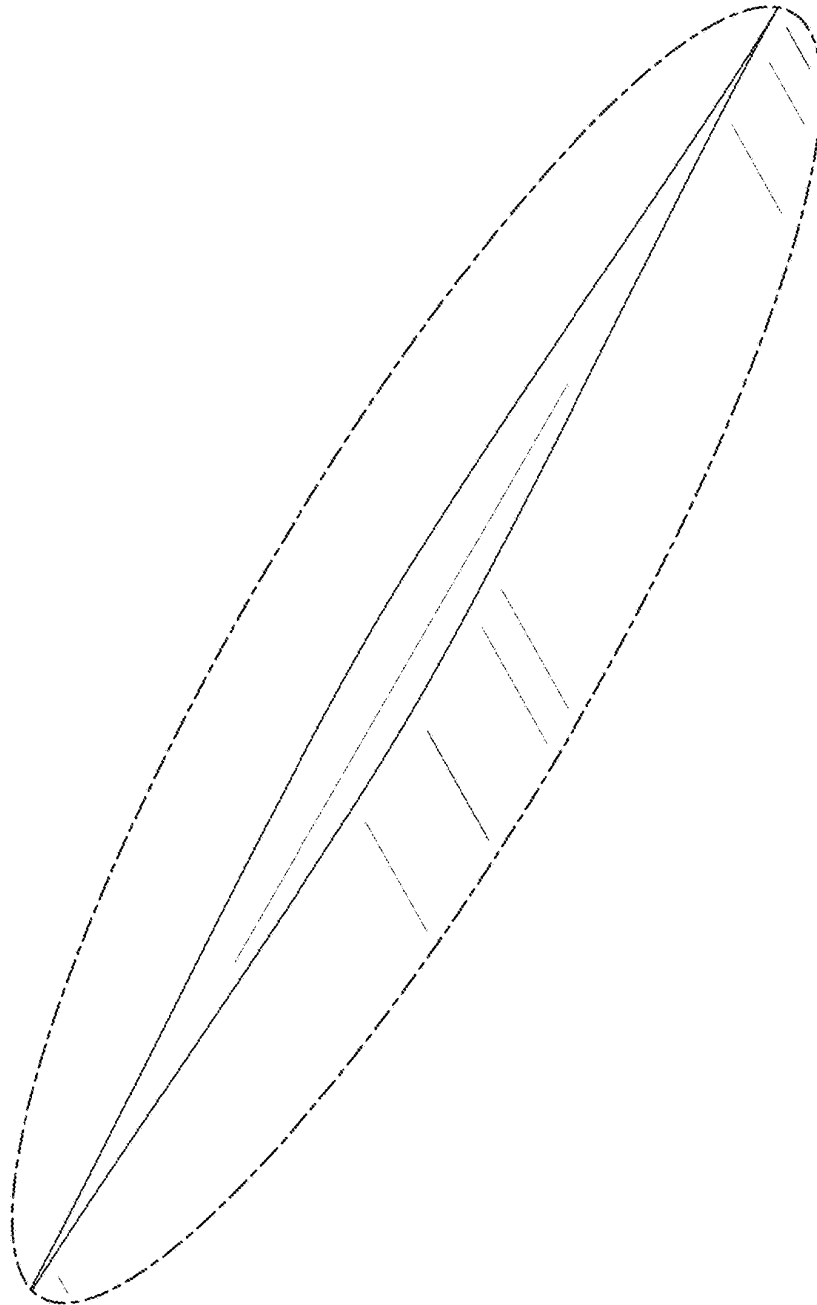

FIG. 61

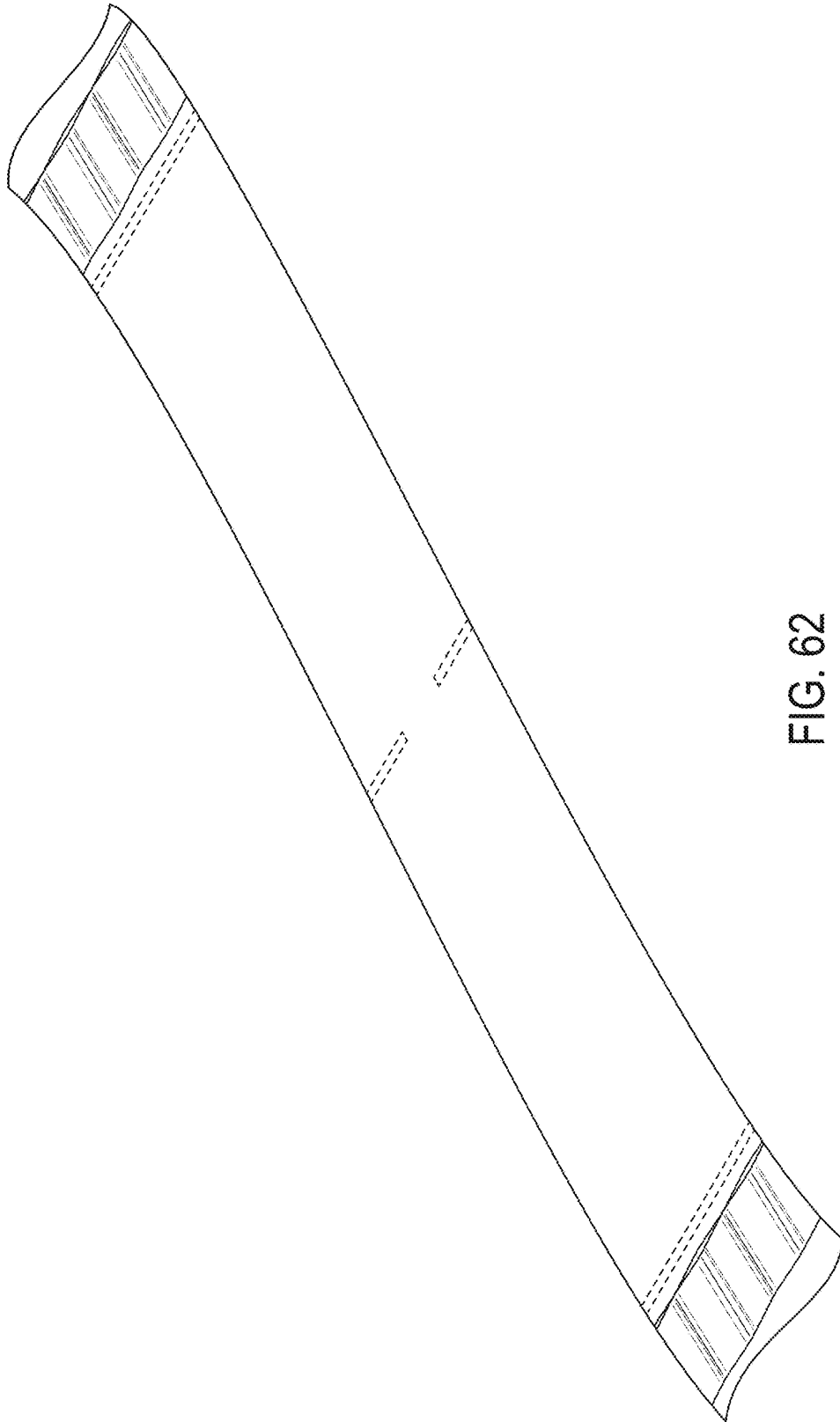

FIG. 62

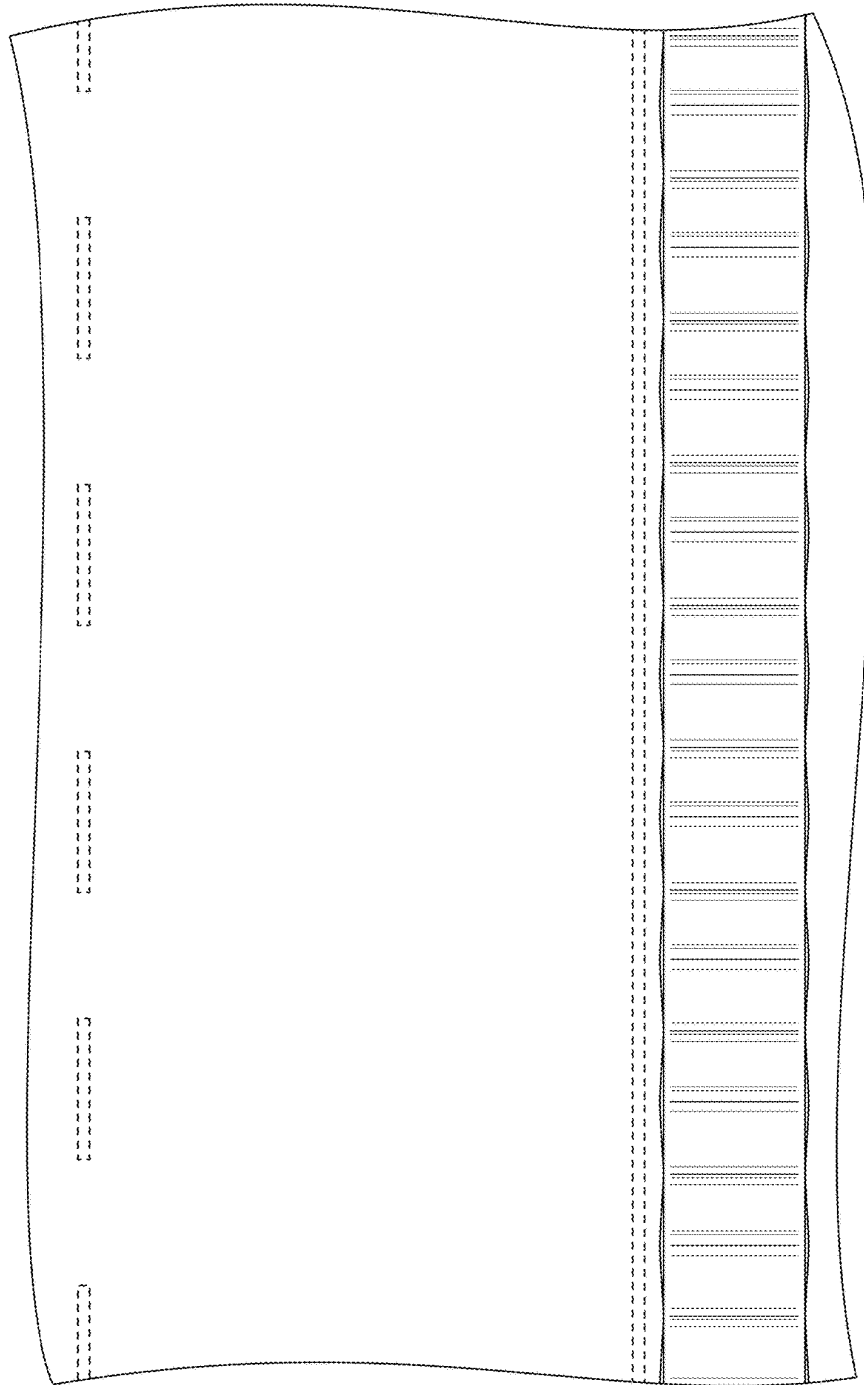

FIG. 63